

### Series HTP25 – singleturn, PWM output

#### Key features HTP25:

- PWM signal output
- Frequency 244 Hz (constant)
- Pulse width (duty cycle) 10% (0°) to 90% (360°)
- Supply voltage: 5 VDC +/-10%



### Electrical data HTP25 – singleturn, PWM output

Effective electrical angle of rotation 1.)	$7^\circ \leq \alpha \leq 360^\circ$ (programmable in factory), $\pm 0.5^\circ$
Independent linearity (best straight line) 1.)	$\pm 0.4\%$ @ 360°
Absolute Linearity 1.)	$\pm 0.6\%$ @ 360°
Output signal	PWM (pulse width modulation)
Output signal voltage	5 V
Carrier frequency	244 Hz (constant)
Minimum duty cycle	10%, equal to app. 0.4 ms
Maximum duty cycle	90%, equal to app. 3.5 ms
Resolution	12 Bit
Supply voltage	5 V $\pm 10\%$
Power consumption (no load)	$\leq 10$ mA
Output load	$\geq 5$ kOhm
Insulation voltage 1.)	1000 VAC @ 50 Hz, 1 min
Insulation resistance 1.)	2 MOhm @ 500 VDC, 1 min
MTTF (EN29500-2005-1)	1267a

1.) According IEC 60393

### Function description PWM signal output HTP25

The HTP25 provides a constant carrier frequency with 244 Hz at the signal output, with HIGH and LOW signal levels which have a constant signal amplitude. A constant carrier frequency means a constant length of the period duration. The duty cycle and thus the pulse width changes in dependency of the rotating angle between 10% to 90% relative to the signal period. If the CW option is selected, the duty cycle increases clockwise when turning the shaft clockwise. If the CCW option is selected, the duty cycle decreases clockwise if the shaft is turned clockwise. Normally no signal conversion is required for further processing of the output signal, because many  $\mu$ Controllers already have an input for PWM signals.

Order code HTP25 – singleturn, PWM output					
Description	Selection: standard= <b>black/bold</b> , possible options= <i>grey/italic</i>				
<b>Series</b>	<b>HTP25</b>				
<b>Shaft diameter, shaft length:</b> Shaft diameter $\varnothing$ 6 mm, shaft length 12 mm <i>Shaft diameter <math>\varnothing</math> 4 mm, shaft length 10 mm</i> <i>Custom shaft dimensions [mm] <math>\varnothing \leq 6.35</math> mm</i>		<b>6x12</b> <i>4x10</i> <i>XxXX</i>			
<b>Supply voltage / output signal:</b> <b>VSUP=5 V (4.5 to 5.5 V) / OUT=5 V / 244 Hz / PWM 10-90%</b>			<b>5PWM</b>		
<b>Sense of rotation:</b> (when looking at the shaft, from the front) <b>Clockwise</b> <i>Counterclockwise</i>				<b>CW</b> <i>CCW</i>	
<b>Rotation angle* in [°]:</b> <b>360</b> <i>320</i> <i>270</i> <i>180</i> <i>90</i> <i>Custom rotation angle (<math>\geq 7^\circ</math>, positive integer)</i>					<b>360</b> <i>320</i> <i>270</i> <i>180</i> <i>90</i> <i>XXX</i>
<b>Electrical connection, cable length:</b> <b>1 m round cable, axial</b> <b>1 m round cable, radial</b> <b>Connector M8, 3-pol., axial</b> <b>Connector M8, 3-pol., radial</b> <i>Round cable, customer-specific cable length [X.XX m], axial</i> <i>Round cable, customer-specific cable length [X.XX m], radial</i>					<b>PG</b> <b>PGR</b> <b>M8</b> <b>M8R</b> <i>PGX,XX</i> <i>PGRX,XX</i>

\* For details see page 29.

Order example HTP25 – singleturn, PWM output
<b>Requirement:</b> Shaft $\varnothing$ 6.36 mm, shaft length 12 mm, VSUP=5 V / OUT=244 Hz, sense of rotation CW, rotation angle 360°, M8 connector
<b>Example for order code:</b> HTP25 6,35x12 5PWM CW 360 M8

Cable and pin assignment			
Function	Option PG(R)	Option M8(R)	Accessory: M8-Connector
OUT	brown	Pin 3	Pin 3 - blue
VSUP	red	Pin 1	Pin 1 - brown
GND	black	Pin 4	Pin 4 - black

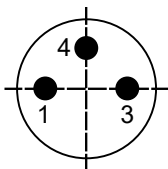
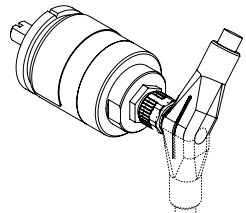
Connector M8 (R) – pin assignment for 3-pin connector		
 <p>Pin-Numbering of socket connector in the encoder housing</p>	<p>The orientation of the connector relative to the encoder body is not defined and varies from encoder to encoder. When using right-angle connectors in combination with axial outlets, the orientation of the cable outlet is therefore not defined.</p> <p>If you need a defined orientation of the cable outlet, please choose our housings with radial cable outlet and use straight mating connectors.</p>	 <p>Orientation will vary when using angled connectors.</p>

**For details on zero point definition and output programming see page 29.**

Drawing HTx25 - axial versions (option PG and M8), shaft dimensions, drilling pattern and zero position

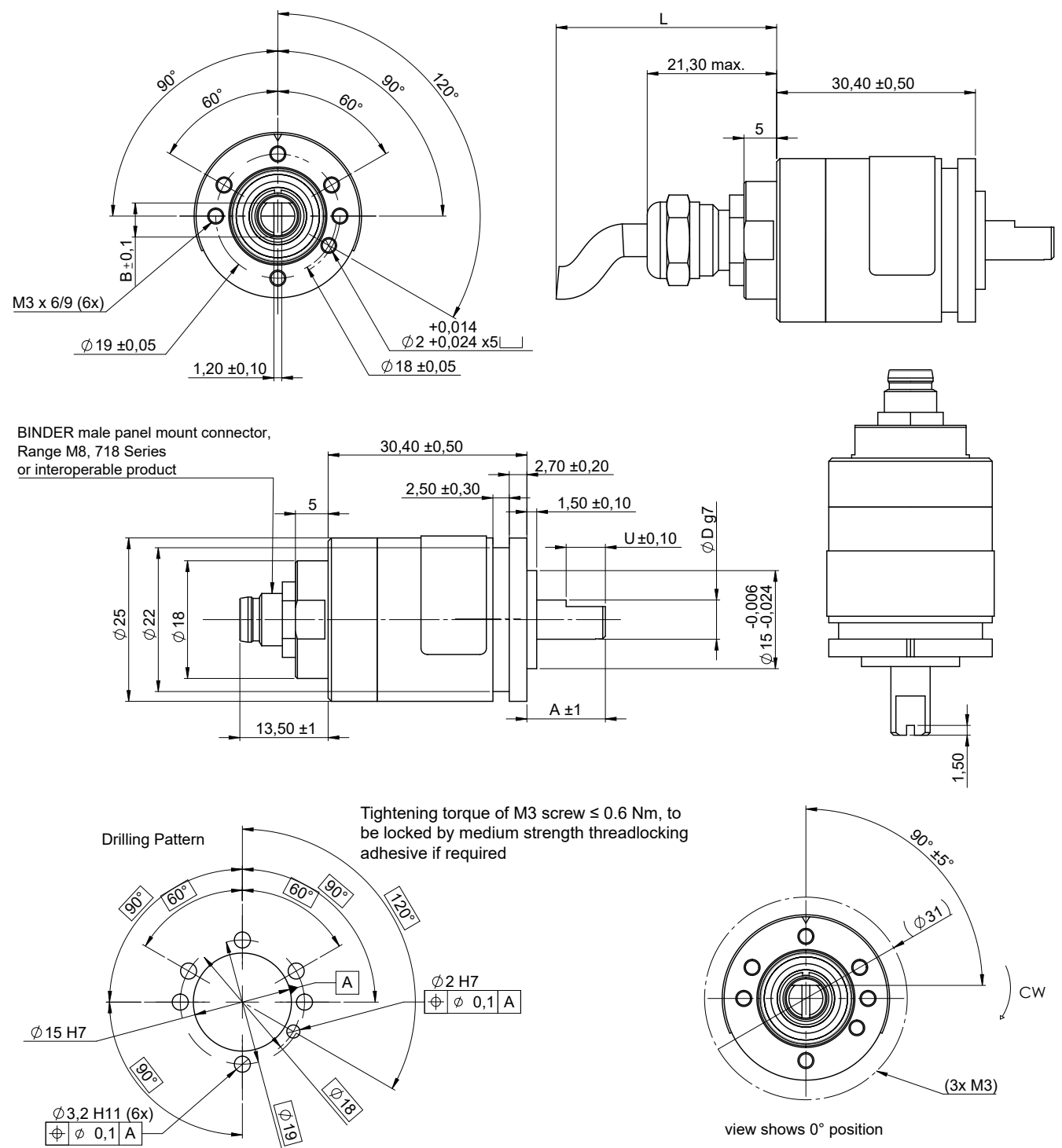

Standard shaft dimensions / tolerances

	Standard type 6 mm	Standard type 4 mm	Other types $\leq 6.35 \text{ mm}$
Shaft length A	12 +/- 1 mm,	10 +/- 1 mm	A (custom length)
Shaft diameter D	6 h9 mm	4 h9 mm	D h9 (custom diameter)
Shaft flattening U length	6 +/- 0.1 mm	1 +/- 0.1 mm	6 +/- 0.1 mm
Shaft flattening B	4.5 +/- 0.1 mm	3.5 mm +/- 0.1 mm	D - 1 mm +/- 0.1 mm

All dimensions in mm

Drawings HTx25 – Radial cable versions with orientation

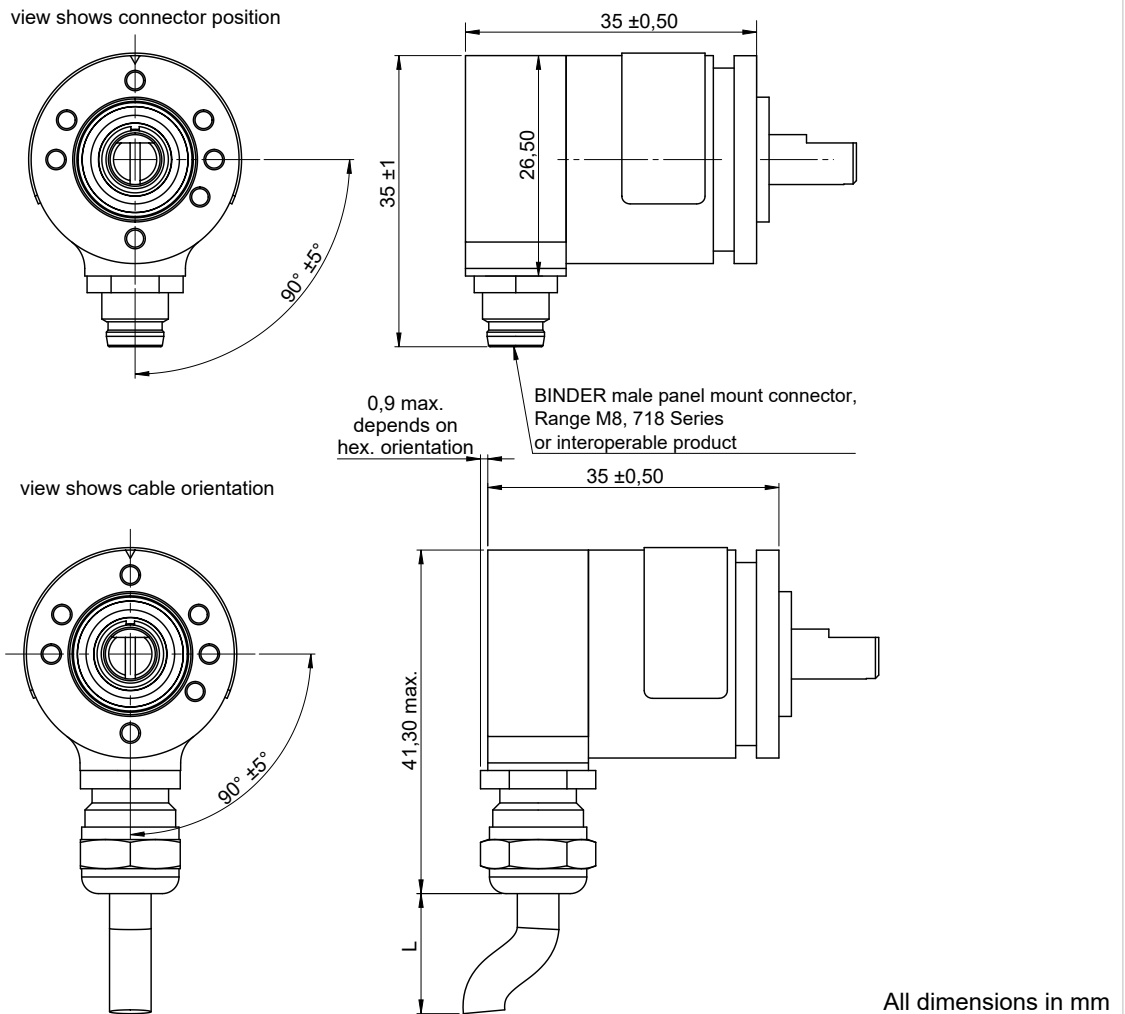

Cable specs for option PG(R) (round control cable)

Option	Standard cable length L	Number of single strands (depends on electronics)	Cable sheath Ø or width	Single strands cross section	Allowed tolerance (L)	Minimum bending radius
PG PGR	Standard 1000 mm	3		AWG26	-20 mm to +40 mm	10 x D Ø (D = cable sheath diameter Ø)
		6				
		8				
		10		AWG28		
		12				

Cables without cable shield

(\*) Tolerances according IPC Association

Cable length tolerances – custom lengths

Length L	Tolerance
≤ 0.3 m	+25 mm / -20 mm
> 0.3 m - 1.5 m	+40 mm / -20 mm
> 1.5 m - 3 m	+100 mm / -40 mm
> 3 m - 7.5 m	+150 mm / -60 mm

Wire harness length measured from sensor face including connector. Minimum cable length: 0.08 m (for round cable). Please contact us for lengths > 3 m regarding handling and packaging.

Mechanical and Environmental data	
Shaft type	Solid shaft
Mechanical angle of rotation 1.)	Endless
Lifetime 2.)	@100 % of max. permissible radial shaft load >1.4x10E8 shaft revolutions @80 % of max. permissible radial shaft load >2x10E9 shaft revolution @20 % of max. permissible radial shaft load >1.7x10E10 shaft revolutions
Bearing	2 pcs. groove ball bearings type 2RS
Max. operational speed (with shaft sealing)	max. 12.000 rpm
Operational torque: (@ room temperature and 10 rev/min)	≤ 0.3 Ncm
Operating temperature range	Option M8 (connector) ▪ -25 to +80°C Option PG (cable gland incl. cable) ▪ -30 to +85°C Kabel fest verlegt ▪ -10 to +85°C Kabel in Bewegung
Storage temperature range	-30 to +105°C
Protection grade (IEC 60529) front side	IP65S
Protection grade (IEC 60529) rear side	Option PG: IP68 (cable ends excluded) Option M8: IP67 (when mated with IP67 type M8 cable)
Vibration (DIN EN 60068-2-64:2008 + A1: 2019)	±1.5 mm / 30 g / 10 to 2000 Hz / 16 frequency cycles (3x4 h)
Shock (DIN EN 60068-2-27)	400 m/s <sup>2</sup> / 6 ms / half sine (100±5) shocks
Housing diameter	Ø 25 mm
Housing depth	In dependency to the electrical connection position: ▪ axial 51.7 mm (PG) / 43.9 mm (M8) ▪ radial 35 mm
Shaft diameter	Standards: Ø6 mm, Ø4 mm, details see drawings Option Custom diameter [mm] Ø ≤ 6.35 mm
Max. radial load	80 N (load point 80% in dependency to the visible standard shaft length)
Max. axial load	40 N (axial application of force onto the shaft end)
Masse (zirka)	HTx25 mit Stecker M8(R) 40 g HTx25 mit Kabelverschraubung und 1 m Signalkabel PG(R) 69 g

1.) According IEC 60393

2.) Determined by climatic conditions according to IEC 68-1, para. 5.3.1 without load collectives

**Mechanical and environmental data, miscellaneous**

Sensor mounting	<ol style="list-style-type: none"> <li>Via threaded holes integrated in the sensors head by use of stainless steel screws M3x0.5</li> <li>Via synchro flange with optional available servo mount fixing nails SFN1 incl. screws M3 x 0.5 from MEGATRON (not enclosed), recommended at angles of 120°</li> </ol>
Mounting hardware included	<p>none</p> <ul style="list-style-type: none"> <li>To attach the rotary encoder using a synchro flange, the MEGATRON SFN1 synchro clamps available as accessories</li> <li>For the electrical connection option M8 (R), cables and mating connectors are not part of the scope of delivery. M8 connectors with cables are available as accessories from MEGATRON</li> </ul>
Fastening torque per screw for fastening of the rotary encoder	<p>≤ 0.6 Nm (M3 screw, thread tensile strength class 5.6) For screw securing, the use of a medium-strength thread securing adhesive is recommended</p>
Material shaft	Stainless steel
Material housing	Aluminium
Material cable gland (PG)	Stainless steel
Material connector M8	CuZn nickel-plated



Servo mount using fixing nails SFN1  
incl. 3 screws M3 x 0.5

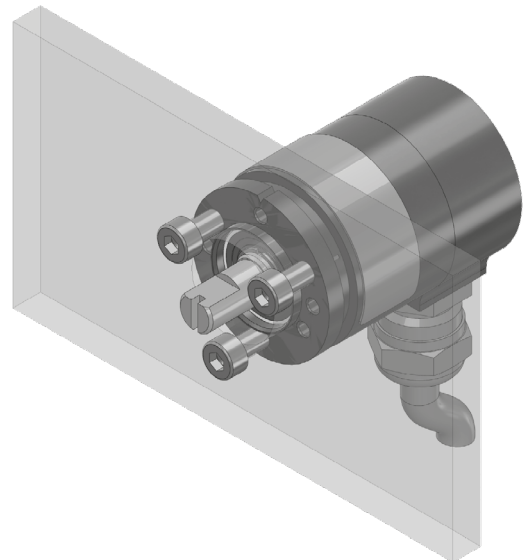

Flange mount using 3 screws M3

**Immunity / Electrostatic Discharge**

EN 61000-4-3 RF sine wave	Class A
EN 61000-4-6 Conducted sine wave	Class A
EN 61000-4-8 Power frequency magnetic fields	Class A
EN 61000-4-2 ESD	Class B

**Definition of the zero position / anti-rotation pin**

**Output at the zero point:**

- HTA25 (analogue outputs): Output signal 0% full scale (F. S.)
- HTP25 (PWM output): duty cycle 10% (10% duty cycle)
- HTS25 (serial output): Output signal 0% full scale (F. S.)
- HTI25 (incremental output): The index signal is output (Z)

Position of the zero position see drawing below (nodge at top)

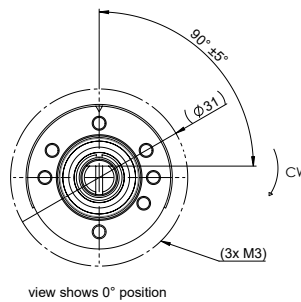

**Signal definition for custom rotation angles**

Custom angles <360°

When programming the electrical angle of rotation of <360°, the remaining non-effective range of rotation is divided equally into high and low.

