

Series HTA25

Key features HTA25:

- Analogue outputs 0 to 5 V, 0 to 10 V, 4 to 20 mA
- Redundant versions available – see separate section
- Several factory programming possibilities
- Supply voltages: 5 VDC $\pm 10\%$, 15 to 30 VDC, 9 to 30 VDC



Electrical data

Effective electrical angle of rotation 1.)	$7^\circ \leq \alpha \leq 360^\circ$ (programmable in factory), $\pm 0.5^\circ$		
Independent linearity (best straight line) 1.)	$\pm 0.3\%$ @ 360°		
Absolute Linearity 1.)	$\pm 0.6\%$ @ 360°		
Output signal	0 to 5 V ratiometric	0 to 10 V	4 to 20 mA
Resolution	12 Bit		
Update rate	200 μ s		
Supply voltage	5 V $\pm 10\%$	15 to 30 V	9 to 30 V
Power consumption (no load)	≤ 18 mA		
Output load	≥ 5 kOhm		≤ 500 Ohm
Insulation voltage 1.)	1000 VAC @ 50 Hz, 1 min		
Insulation resistance 1.)	2 MOhm @ 500 VDC, 1 min		
MTTF (EN29500-2005-1)	1173a	965a	379a

1.) According IEC 60393

Wire colour/pin assignment

Function:	Option PG(R)	Option M8(R)	Accessory: M8-Connector
OUT	brown	Pin 3	Pin 3 - blue
VSUP	red	Pin 1	Pin 1 - brown
GND	black	Pin 4	Pin 4 - black

Connector M8 (R) – pin assignment for 3-pin connector

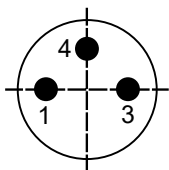

Pin-Numbering of socket connector in the encoder housing

The orientation of the connector relative to the encoder body is not defined and varies from encoder to encoder. When using right-angle connectors in combination with axial outlets, the orientation of the cable outlet is therefore not defined.

If you need a defined orientation of the cable outlet, please choose our housings with radial cable outlet and use straight mating connectors.

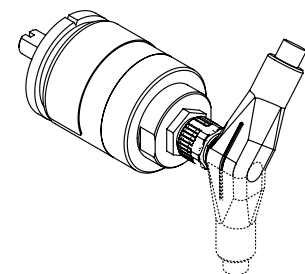

Orientation will vary when using angled connectors.

For details on zero point definition and output programming see page 29.

Order code HTA25 – singleturn, analogue output, not redundant					
Description	Selection: standard= black/bold , possible options= <i>grey/italic</i>				
Series	HTA25				
Shaft diameter, shaft length: Shaft diameter Ø 6 mm, shaft length 12 mm <i>Shaft diameter Ø 4 mm, shaft length 10 mm</i> <i>Custom shaft dimensions [mm] Ø ≤ 6.35 mm</i>		6x12 <i>4x10</i> <i>XxXX</i>			
Supply voltage / output signal: VSUP=5 V (4.5 to 5.5 V) / OUT=0 to 5 V (<i>ratiometric</i>) VSUP=24 V (15 to 30 V) / OUT=0 to 10 V VSUP=24 V (9 to 30 V) / OUT=4 to 20 mA <i>VSUP=24 V (9 to 30 V) / OUT=0 to 5 V</i>			0505 2410 2442 <i>2405</i>		
Sense of rotation: (when looking at the shaft, from the front) Clockwise <i>Counterclockwise</i>				CW <i>CCW</i>	
Rotation angle* in [°]: 360 <i>320</i> <i>270</i> <i>180</i> <i>90</i> <i>Custom rotation angle (≥7°, positive integer)</i>				360 <i>320</i> <i>270</i> <i>180</i> <i>90</i> <i>XXX</i>	
Electrical connection, cable length: 1 m round cable, axial 1 m round cable, radial Connector M8, 3-pol., axial Connector M8, 3-pol., radial <i>Round cable, customer-specific cable length [X,XX m], axial</i> <i>Round cable, customer-specific cable length [X,XX m], radial</i>					PG PGR M8 M8R <i>PGX,XX</i> <i>PGRX,XX</i>

* For details see page 29.

Order example HTA25
Requirements: Shaft Ø 6.00 mm, shaft length 12 mm, VSUP=5 V / OUT=0 to 5 V, sense of rotation CW, rotation angle 360° round cable 1.00 m
Example for order code: HTA25 6x12 0505 CW360 PG

Series HTA25X – singleturn, analogue output, redundant

Key features HTA25X :

- Independent signal processing. The HTA25X rotary encoder electronics are based mainly on one Hall IC in which two semiconductor dies independently capture, evaluate and output the measured values
- Supply voltage, signal output and ground are galvanically insulated => separate electrical connections
- Supply voltages: 2 x 5 VDC or 2 x 15 to 30 VDC
- Signal outputs: 2 x 0 to 5 V or 2 x 0 to 10 V

Electrical data HTA25X – singleturn, analogue output, redundant

Effective electrical angle of rotation 1.)	7° ≤ α ≤ 360° (programmable at factory), ±0.5°	
Independent linearity (best straight line) 1.)	±0.3% @ 360°	
Absolute Linearity 1.)	±0.6% @ 360°	
Output signal	0 to 5 V ratiometric	0 to 10 V
Resolution	12 Bit	
Update rate	200 μs	
Supply voltage	5 V ±10%	15 to 30 V
Power consumption (no load)	≤ 23 mA	
Output load	≥ 5 kOhm	
Insulation voltage 1.)	1000 VAC @ 50 Hz, 1 min	
Insulation resistance 1.)	2 MOhm @ 500 VDC, 1 min	
MTTF (EN29500-2005-1)	613a	202a

1.) According IEC 60393

Cable and pin assignment HTA25X – singleturn, analogue output, redundant

Function:	Option PG(R)	Option M8(R)	Accessory: M8-Connector
VSUP 1	red	1	Pin 1 - white
OUT 1	brown	2	Pin 2 - brown
GND 1	black	3	Pin 3 - green
GND 2	green	4	Pin 4 - yellow
OUT 2	yellow	5	Pin 5 - grey
VSUP 2	orange	6	Pin 6 - pink
n/c	-	7	Pin 7 - blue
n/c	-	8	Pin 8 - red

Connector M8 (R) – pin assignment for 8-pin connector

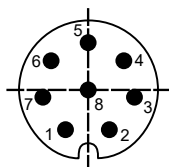

Pin-Numbering of socket connector in the encoder housing

The orientation of the connector relative to the encoder body is not defined and varies from encoder to encoder. When using right-angle connectors in combination with axial outlets, the orientation of the cable outlet is therefore not defined.

If you need a defined orientation of the cable outlet, please choose our housings with radial cable outlet and use straight mating connectors.

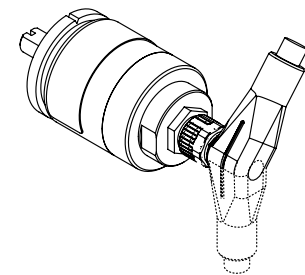

Orientation will vary when using angled connectors.

For details on zero point definition and output programming see page 29.

Order code HTA25X – redundant, singleturn, analogue output

Description	Selection: standard= black/bold , possible options= <i>grey/italic</i>				
Series	HTA25X				
Shaft diameter, shaft length: Shaft diameter Ø 6 mm, shaft length 12 mm <i>Shaft diameter Ø 4 mm, shaft length 10 mm</i> <i>Custom shaft dimensions [mm] Ø ≤ 6.35 mm</i>		6x12 <i>4x10</i> <i>XxXX</i>			
Supply voltage / output signal: VSUP=5 V (4.5 to 5.5 V) / OUT=0 to 5 V (<i>ratiometric</i>) VSUP=24 V (15 to 30 V) / OUT=0 to 10 V			0505 2410		
Sense of rotation: (when looking at the shaft, from the front) Clockwise/Clockwise (ganging) <i>Clockwise/Counterclockwise (counterrotational)</i>				CW CW <i>CW CCW</i>	
Rotation angle* in [°]: 360 <i>320</i> <i>270</i> <i>180</i> <i>90</i> <i>Custom rotation angle (≥7°, positive integer)</i>					360 <i>320</i> <i>270</i> <i>180</i> <i>90</i> <i>XXX</i>
Electrical connection, cable length: 1 m round cable, axial 1 m round cable, radial Connector M8, 8-pol., axial Connector M8, 8-pol., radial <i>Round cable, customer-specific cable length [X.XX m], axial</i> <i>Round cable, customer-specific cable length [X.XX m], radial</i>					PG PGR M8 M8R <i>PGX,XX</i> <i>PGRX,XX</i>

* For details see page 29.

Order example HTA25X – redundant, singleturn, analogue output
Requirement:

Redundant, shaft Ø 6.00 mm, shaft length 12 mm, VSUP=5 V /OUT=0...5 V, signal 1 sense of rotation CW, signal 2 sense of rotation CW, electrical rotation 360° signal 1 and 2, M8 plug radial, 8 pin

Example for order code:

HTA25X 6x12 0505 CW CW 360 M8R

Drawing HTx25 - axial versions (option PG and M8), shaft dimensions, drilling pattern and zero position

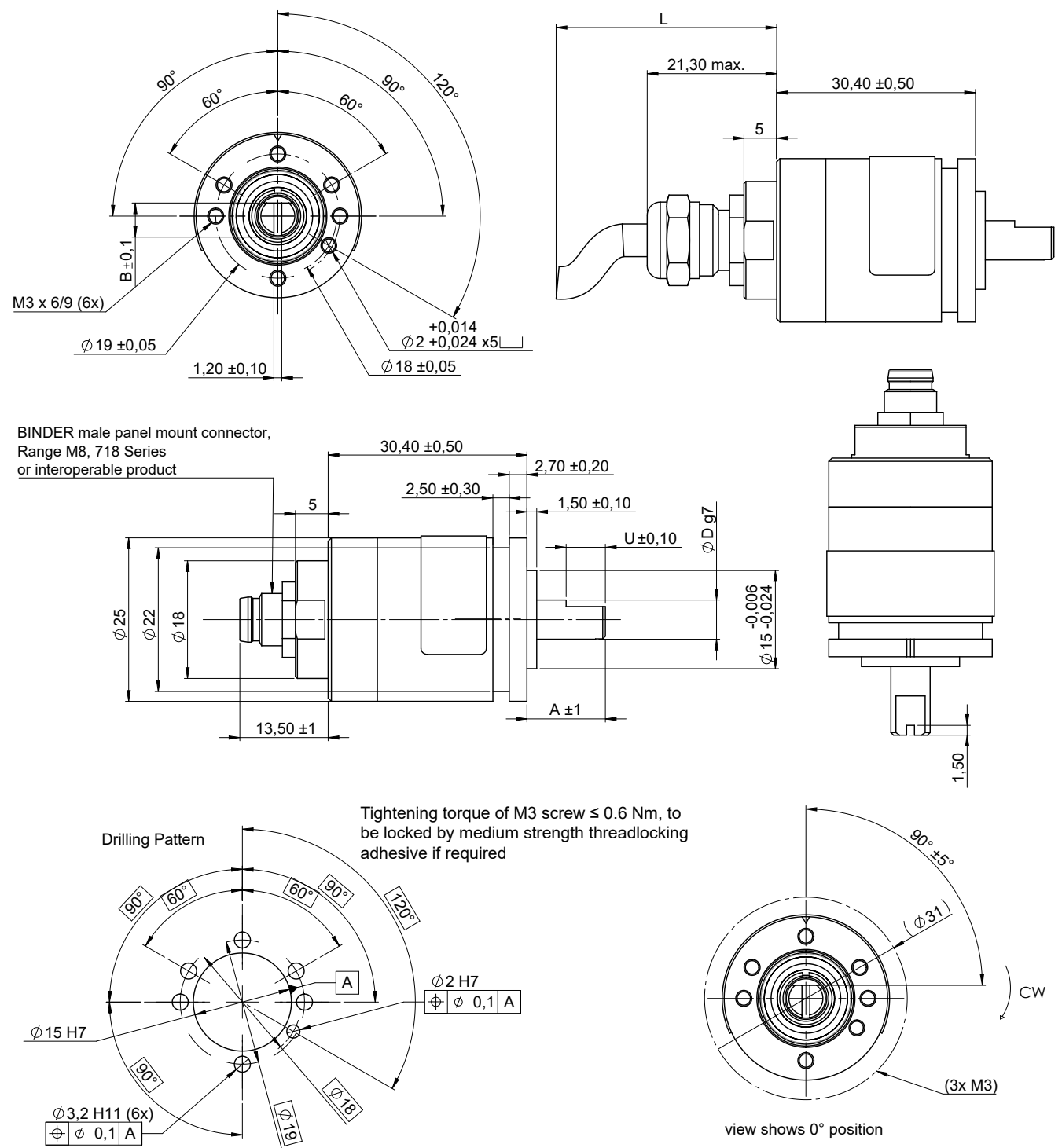

Standard shaft dimensions / tolerances

	Standard type 6 mm	Standard type 4 mm	Other types $\leq 6.35 \text{ mm}$
Shaft length A	12 +/- 1 mm,	10 +/- 1 mm	A (custom length)
Shaft diameter D	6 h9 mm	4 h9 mm	D h9 (custom diameter)
Shaft flattening U length	6 +/- 0.1 mm	1 +/- 0.1 mm	6 +/- 0.1 mm
Shaft flattening B	4.5 +/- 0.1 mm	3.5 mm +/- 0.1 mm	D - 1 mm +/- 0.1 mm

All dimensions in mm

Drawings HTx25 – Radial cable versions with orientation

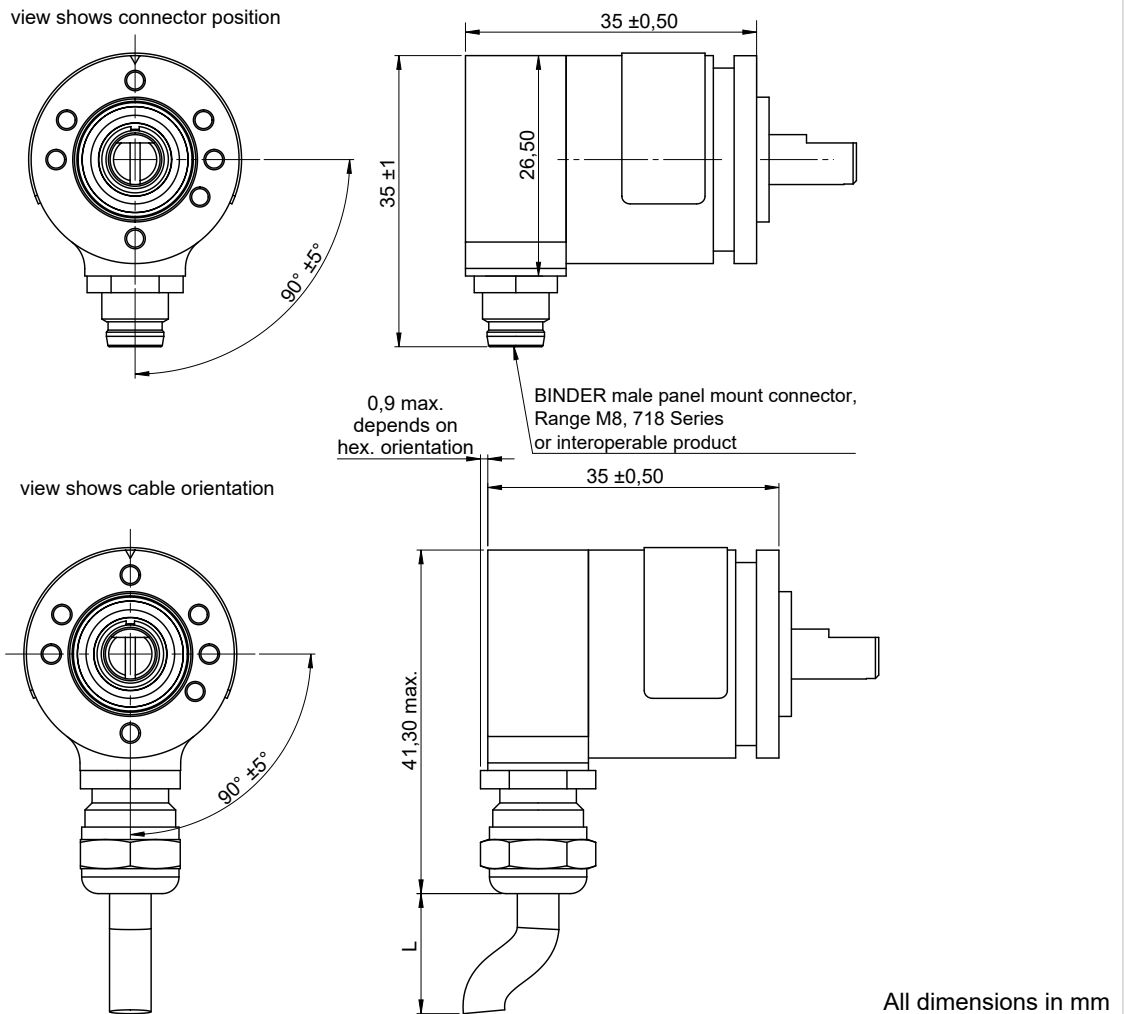

Cable specs for option PG(R) (round control cable)

Option	Standard cable length L	Number of single strands (depends on electronics)	Cable sheath Ø or width	Single strands cross section	Allowed tolerance (L)	Minimum bending radius
PG PGR	Standard 1000 mm	3		AWG26	-20 mm to +40 mm	10 x D Ø (D = cable sheath diameter Ø)
		6				
		8				
		10				
		12		AWG28		

Cables without cable shield

(*) Tolerances according IPC Association

Cable length tolerances – custom lengths

Length L	Tolerance
≤ 0.3 m	+25 mm / -20 mm
> 0.3 m - 1.5 m	+40 mm / -20 mm
> 1.5 m - 3 m	+100 mm / -40 mm
> 3 m - 7.5 m	+150 mm / -60 mm

Wire harness length measured from sensor face including connector. Minimum cable length: 0.08 m (for round cable). Please contact us for lengths > 3 m regarding handling and packaging.

Mechanical and Environmental data	
Shaft type	Solid shaft
Mechanical angle of rotation 1.)	Endless
Lifetime 2.)	@100 % of max. permissible radial shaft load >1.4x10E8 shaft revolutions @80 % of max. permissible radial shaft load >2x10E9 shaft revolution @20 % of max. permissible radial shaft load >1.7x10E10 shaft revolutions
Bearing	2 pcs. groove ball bearings type 2RS
Max. operational speed (with shaft sealing)	max. 12.000 rpm
Operational torque: (@ room temperature and 10 rev/min)	≤ 0.3 Ncm
Operating temperature range	Option M8 (connector) ▪ -25 to +80°C Option PG (cable gland incl. cable) ▪ -30 to +85°C Kabel fest verlegt ▪ -10 to +85°C Kabel in Bewegung
Storage temperature range	-30 to +105°C
Protection grade (IEC 60529) front side	IP65S
Protection grade (IEC 60529) rear side	Option PG: IP68 (cable ends excluded) Option M8: IP67 (when mated with IP67 type M8 cable)
Vibration (DIN EN 60068-2-64:2008 + A1: 2019)	±1.5 mm / 30 g / 10 to 2000 Hz / 16 frequency cycles (3x4 h)
Shock (DIN EN 60068-2-27)	400 m/s ² / 6 ms / half sine (100±5) shocks
Housing diameter	Ø 25 mm
Housing depth	In dependency to the electrical connection position: ▪ axial 51.7 mm (PG) / 43.9 mm (M8) ▪ radial 35 mm
Shaft diameter	Standards: Ø6 mm, Ø4 mm, details see drawings Option Custom diameter [mm] Ø ≤ 6.35 mm
Max. radial load	80 N (load point 80% in dependency to the visible standard shaft length)
Max. axial load	40 N (axial application of force onto the shaft end)
Masse (zirka)	HTx25 mit Stecker M8(R) 40 g HTx25 mit Kabelverschraubung und 1 m Signalkabel PG(R) 69 g

1.) According IEC 60393

2.) Determined by climatic conditions according to IEC 68-1, para. 5.3.1 without load collectives

Mechanical and environmental data, miscellaneous

Sensor mounting	<ol style="list-style-type: none"> Via threaded holes integrated in the sensors head by use of stainless steel screws M3x0.5 Via synchro flange with optional available servo mount fixing nails SFN1 incl. screws M3 x 0.5 from MEGATRON (not enclosed), recommended at angles of 120°
Mounting hardware included	<p>none</p> <ul style="list-style-type: none"> To attach the rotary encoder using a synchro flange, the MEGATRON SFN1 synchro clamps available as accessories For the electrical connection option M8 (R), cables and mating connectors are not part of the scope of delivery. M8 connectors with cables are available as accessories from MEGATRON
Fastening torque per screw for fastening of the rotary encoder	<p>≤ 0.6 Nm (M3 screw, thread tensile strength class 5.6) For screw securing, the use of a medium-strength thread securing adhesive is recommended</p>
Material shaft	Stainless steel
Material housing	Aluminium
Material cable gland (PG)	Stainless steel
Material connector M8	CuZn nickel-plated

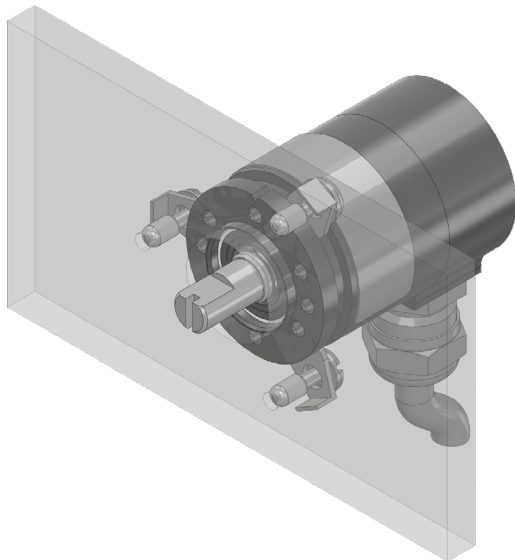

Servo mount using fixing nails SFN1
incl. 3 screws M3 x 0.5

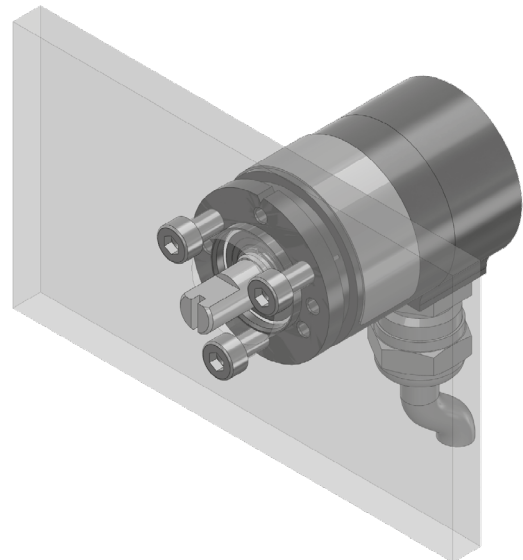

Flange mount using 3 screws M3

Immunity / Electrostatic Discharge

EN 61000-4-3 RF sine wave	Class A
EN 61000-4-6 Conducted sine wave	Class A
EN 61000-4-8 Power frequency magnetic fields	Class A
EN 61000-4-2 ESD	Class B

Definition of the zero position / anti-rotation pin

Output at the zero point:

- HTA25 (analogue outputs): Output signal 0% full scale (F. S.)
- HTP25 (PWM output): duty cycle 10% (10% duty cycle)
- HTS25 (serial output): Output signal 0% full scale (F. S.)
- HTI25 (incremental output): The index signal is output (Z)

Position of the zero position see drawing below (nodge at top)

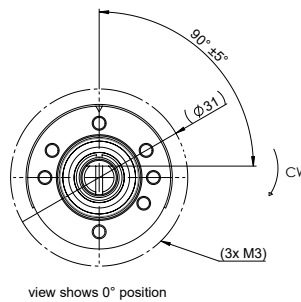

Signal definition for custom rotation angles

Custom angles <360°

When programming the electrical angle of rotation of <360°, the remaining non-effective range of rotation is divided equally into high and low.

