

Series ETS25K – singleturn, digital output, not redundant

Key features ETS25F:

- Efficient, fast signal transmission (length of signal lines limited by clock rate)
- Synchronous Serial Interface (SSI, 10 to 18 bit) or
- Serial Peripheral Interface (SPI, 14 bit)

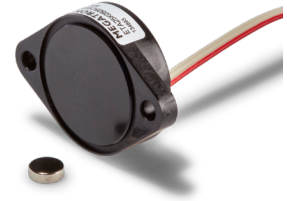

Electrical data ETS25K – singleturn, digital output, not redundant

Output signal	SPI	SSI (binary code)
Effective electrical angle of rotation 1.)		360°
Independent linearity (best straight line) 1.)		±0.3% @ 360°
Resolution	14 Bit	10 to 18 Bit
Supply voltage V_{SUP}	5 VDC ±10%	5 to 30 V
Power consumption (no load)	≤ 12 mA	
Insulation voltage 1.)		1000 VAC @ 50 Hz, 1 min
Insulation resistance 1.)		2 MOhm @ 500 VDC, 1 min
MTTF (EN29500-2005-1)	2046a	-
Voltage level at output	5 V	±5 V (differential voltage 10 V)
Max. data- / clock rate	siehe details of SPI protocoll	4 MHz

1.) According to IEC 60393

Order code ETS25K – singleturn, digital output, not redundant

Description	Selection: standard= black/bold , possible options= <i>grey/italic</i>		
Series	ETS25K		
Supply voltage / output signal: SPI (14 Bit) / $V_{SUP} = 5 \text{ VDC} \pm 10\%$ SSI, 16 bit / $V_{SUP} = 5...30 \text{ V}$ <i>SSI, custom resolution 10..18 bit / $V_{SUP} = 5...30 \text{ V}$</i>		05SPI SSI <i>SSI [10-18]</i>	
Electrical connection, cable length: Flat ribbon cable, standard length 0.15 m <i>Flat ribbon cable with custom length [x.xx m]</i> <i>Round cable, standard length 1 m</i> <i>Round cable with custom length [x.xx m] (max. 1 m for SPI, recommended < 15 cm)</i>			F0,15 <i>FX,XX</i> <i>R1,00</i> <i>RX,XX</i>

Order example ETS25K – singleturn, digital output, not redundant

Requirement:

14 Bit/5 VDC/SPI, flat ribbon cable 0.15 m

Example for order code:

ETS25K 05SPI F0,15

Cable/colour assignment – Option 05SPI, not redundant		
Function:	Option R (round signal cable)	Option F (flatribbon cable)
VSUP	red	Lead 1
GND	black	Lead 2
CS, MOSI	yellow	Lead 3
CLK	green	Lead 4
DATA	orange	Lead 5
-	brown n/c	

Cable/colour assignment – option SSI		
Funktion:	Option R (Rundkabel)	Option F (Flachbandkabel)
VSUP	rot	Lead 1 (red)
GND	schwarz	Lead 2
CLK+	brown	Lead 3
CLK-	orange	Lead 4
DATA-	green	Lead 5
DATA+	yellow	Lead 6

Please pay attention to the limiting factors in the cable lengths / transmission limits of the serial communication.

Synchronous Serial Interface (SSI) - A simple yet robust interface

The synchronous serial interface (SSI) is a serial interface, i.e. the individual bits are transmitted in chronological order. The basis of data transmission is a shift register in which the encoder provides its current measured value. The rotary encoders function as so-called SSI slaves, because they only supply the values from the shift register at the DO (data out) output on receipt of a clock sequence sent out by the SSI master, the so-called "clock" signal (CLK). This clock signal is applied to the CLK input of the encoder. Both the clock signal and the data signal are transmitted differentially, which makes this type of data interface particularly robust against interference. In short, SSI enables the memory of a sensor to be read out reliably from an external source.

Data transmission

The SSI electronics of the encoder reacts to the first falling edge that arrives via the CLK line of the master, loads the current data into the register and transmits it bit by bit to the receiver with each rising edge of the clock. The composition of the transmitted information is not standardised and varies from manufacturer to manufacturer, sometimes even from product to product.

In MEGATRON's encoders, the position information is transmitted first (starting with the Most Significant Bit MSB, ending with the Least Significant Bit LSB). The maximum value of this information is limited by the number of bits transmitted. This is also the resolution of the measurement data. For example, a resolution of 10 bits corresponds to a number of $2^{10} = 1024$ steps, which are divided over the angular range of 360° . Thus, after receiving the position information, it is easy to calculate back to the absolute angle, because each single step would correspond to $360/1024 = 0.35^\circ$.

The position information is followed by a bit sequence of status data that can be of great interest for the application. This includes whether the magnetic field acting on the Hall sensor is within the permissible limits (i.e. the distance of the magnet from the sensor). The last bit is the parity bit. This takes the values HIGH or LOW as required, so that the encoder always sends an even number of bits (even parity). The receiver, i.e. the SSI master, must be set to the total length of the transmitted information including the parity bit.

At the end of the process, the master usually does not send any further edges to the encoder via the CLK line. The encoder then waits for a time t_m (retriggerable monoflop) since the last CLK edge and then updates the data in the shift register. This is therefore the minimum pause time between two consecutive clock sequences when the master requires new, updated measurement data. The exact protocol description of the HTS encoders follows on the next page

Ring shift

However, if clock edges continue to be sent, then the encoder will start transmitting the same data set repeatedly after a zero bit. This procedure is also called ringshift. This makes sense, for example, if the parity bit would be incorrect from the master's point of view, if the data is otherwise corrupt and a new transmission is therefore requested, or if a higher transmission reliability is generally desired by comparing multiple transmissions of the same data. With ring shift, the transmission is also terminated and the latest measurement data is only loaded into the register again when no more clock signals arrive at the encoder for a minimum time t_m .

Early stop

The transmission of the data can be interrupted by the master at any time, e.g. also after the 10th bit. Even then, the internal timer (monoflop) expires, causing the data in the register to be reloaded after the time t_m . In this way, for example, only a part of the encoder data can be read out (e.g. 10 of the available 16 bits, no status data at all) and a higher update rate can be achieved, as the remaining information is simply omitted.

Notes on cable length

The higher the transmission rate (clock rate), the smaller the realisable cable length with SSI. These are physical limits that are not limited by the sensor product itself. A simple blanket statement about the actual realisable length is not easily possible.

The cable length that can actually be realised in the application is influenced by the following factors:

- Quality and design of the cable (shielding, conductor cross-section, conductor resistance, twisted cores, etc.)
- Ambient conditions (sources of interference such as motors, etc.)

We explicitly refer to the RS-422 standard regarding cable lengths.

Protocol description – Synchronous Serial Interface (SSI)

The HTS25K SSI encoder provides a 10-bit to 18-bit absolute position output, while 16 bit is the standard (ex works) configuration. This means that the full rotation angle (360°) is divided into steps of the respective resolution (16 bits yields 65.536 steps of approx. 0.005 degrees).

Standard configuration (16 bit output) yields the following pulse train, consisting both of position and status data:



The data structure for any resolution is as follows:

Position data (10 to 18 bits)				Status (3-bit)			Parity 1 bit
MSB	MSB-1	...	LSB	RDY	MHI	MLO	PAR

Abbreviation	Description
MSB to LSB	n-bits position data, selectable from 10 to 18 bits ex works, standard is 16 bit
RDY	The encoder is ready (if value is HIGH).
MHI	This indicates that the magnet strength detected by the Hall chip is too strong. If this is consistently HIGH, change to a weaker magnet or increase the distance between the encoder and the magnet. The value for this alarm is displayed as 1.
MLO	This indicates that the magnet strength detected by the Hall chip is too weak. If this is consistently HIGH, change to a stronger magnet or decrease the distance between the encoder and the magnet. The value for this alarm is displayed as 1.
PAR	Parity is even

Data is transmitted according to the following timing diagram:

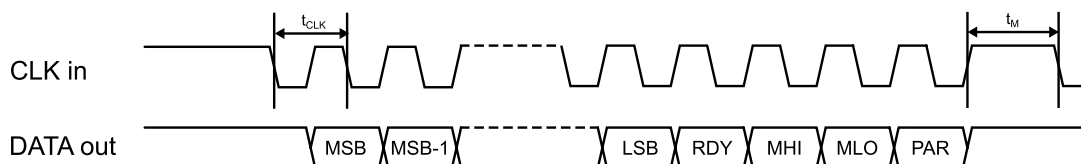

Symbol	Description	Min.	Typ.	Max.
t_{CLK}	Serial clock period	4 μ s		$t_{M/2}$
t_M	monoflop, time between two successive SSI reads		16.5 μ s	18 μ s

Data is latched on the first CLK falling edge and is transmitted on the next falling edge. Both signals are transmitted differentially and therefore have 2 connections (+/-) each. Data will be refreshed when the next monoflop (t_M) expires. If another clock train is sent before this time expires, the same position data is output, and the data is separated by a single low bit:

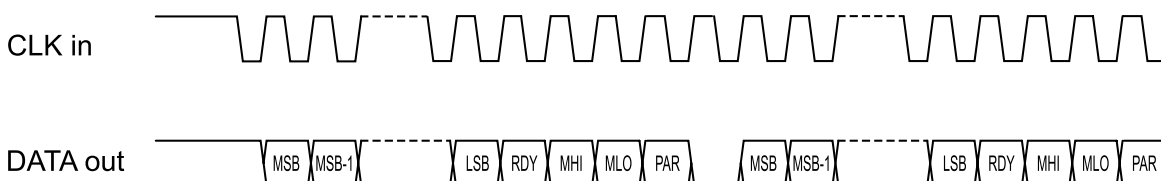

Protocol description ETS25 – Serial Peripheral Interface (SPI)
Introduction

The encoder is configured as a Slave node. The serial protocol of the is a three wires protocol (/SS, SCLK, MOSI-MISO):

- /SS output is a 5 V tolerant digital input
- SCLK output is a 5 V tolerant digital input
- MOSI-MISO output is a 5 V tolerant open drain digital input/output

Basic knowledge of the standard SPI specification is required for the good understanding of the present section.

Even clock changes are used to sample the data. The positive going edge shifts a bit to the Slave's output stage and the negative going edge samples the bit at the Master's input stage.

MOSI (Master Out Slave In)

The Master sends a command to the Slave to get the angle information.

MISO (Master In Slave Out)

The MISO of the slave is an open-collector stage. Due to the capacitive load, a >1 kΩ pull-up is used for the recessive high level (in fast mode). Note that MOSI and MISO use the same physical wire of the ETS25.

/SS (Slave Select)

The /SS output enables a frame transfer. It allows a re-synchronization between Slave and Master in case of a communication error.

Master Start-Up

/SS, SCLK, MISO can be undefined during the Master start-up as long as the Slave is re-synchronized before the first frame transfer.

Slave Start-Up

The slave start-up (after power-up or an internal failure) takes 16 ms. Within this time /SS and SCLK is ignored by the Slave. The first frame can therefore be sent after 16 ms. MISO is Hi-Z (i.e. Hi-Impedance) until the Slave is selected by its /SS input. The encoder will cope with any signal from the Master while starting up.

Timing

To synchronize communication, the Master deactivates /SS high for at least t_5 (1.5 ms). In this case, the Slave will be ready to receive a new frame. The Master can re-synchronize at any time, even in the middle of a byte transfer. Note: Any time shorter than t_5 leads to an undefined frame state, because the Slave may or may not have seen /SS inactive.

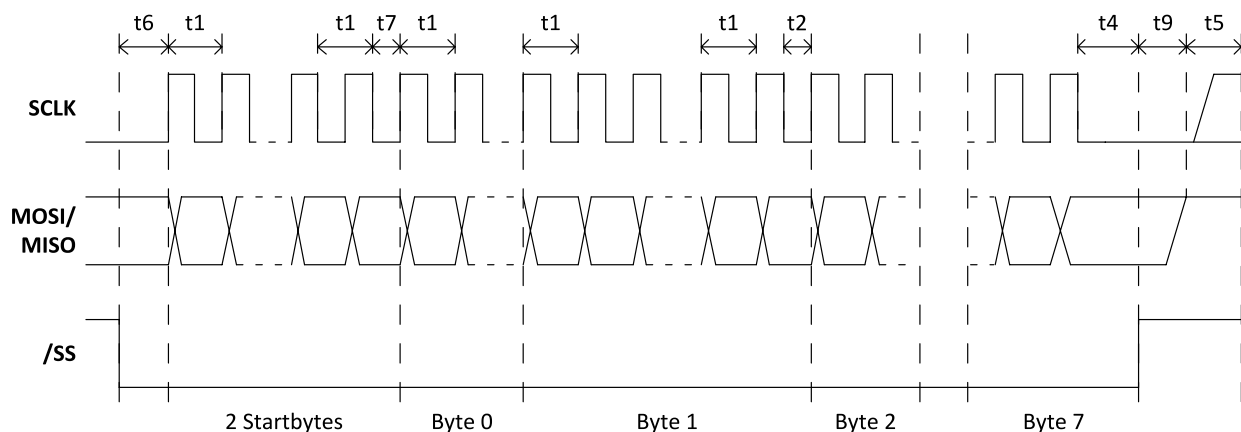

Protocol description ETS25 – Serial Peripheral Interface (SPI) (continuation)
Description Timings

Timings	Min	Max	Remarks
t1	2.3 μ s / 6.9 μ s	-	No capacitive load on MISO. t1 is the minimum clock period for any bits within a byte.
t2	12.5 μ s / 37.5 μ s	-	t2 the minimum time between any other byte
t4	2.3 μ s / 6.9 μ s	-	Time between last clock and /SS=high=chip de-selection
t5	300 μ s / 1500 μ s	-	Minimum /SS = Hi time where it's guaranteed that a frame re-synchronizations will be started
t5	0 μ s	-	Maximum /SS = Hi time where it's guaranteed that NO frame re-synchronizations will be started.
t6	2.3 μ s / 6.9 μ s	-	The time t6 defines the minimum time between /SS = Load the first clock edge
t7	15 μ s / 45 μ s	-	t7 is the minimum time between the StartByte and the Byte0
t9	-	< 1 μ s	Maximum time between /SS = Hi and MISO Bus HighImpedance
T _{Startup}	-	< 10 ms / 16 ms	Minimum time between reset-inactive and any master signal change

Slave Reset

On internal soft failures the Slave resets after 1 second or after an (error) frame is sent. On internal hard failures the Slave resets itself. In that case, the Serial Protocol will not come up. The serial protocol link is enabled only after the completion of the first synchronization (the Master deactivates /SS for at least t5).

Frame Layer
Command Device Mechanism

Before each transmission of a data frame, the Master should send a byte AAh to enable a frame transfer. The latch point for the angle measurement is at the last clock before the first data frame byte.

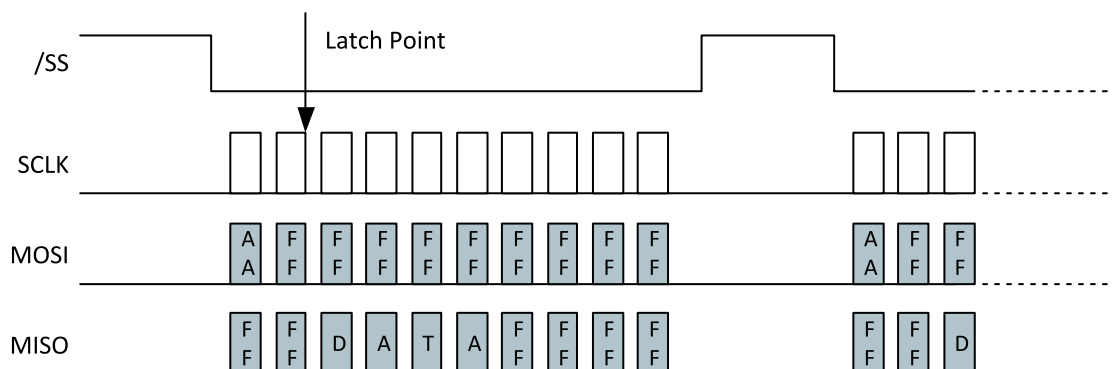

Data Frame Structure

A data frame consists of 10 bytes:

- 2 start bytes (AAh followed by FFh)
- 2 data bytes (DATA16 – most significant byte first)
- 2 inverted data bytes (/DATA16 - most significant byte first)
- 4 all-Hi bytes

The Master should send AAh (55h in case of inverting transistor) followed by 9 bytes FFh. The Slave will answer with two bytes FFh followed by 4 data bytes and 4 bytes FFh.

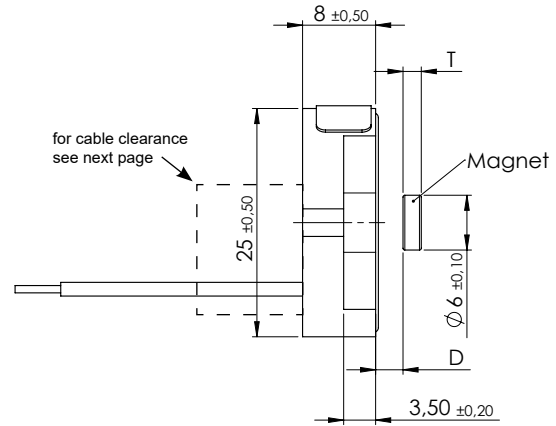
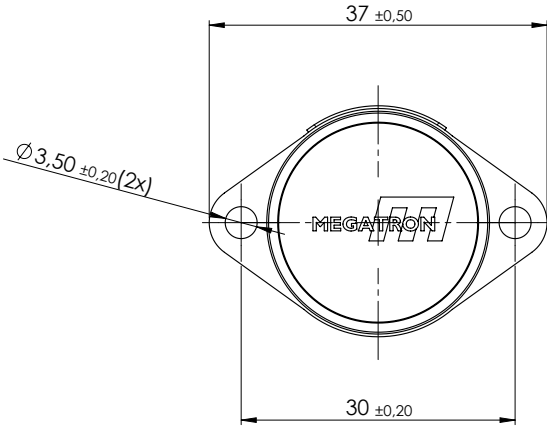
Drawing ETx25K Family



drilling pattern

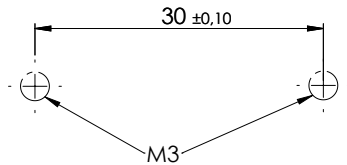

Tightening torque $\leq 0,5\text{Nm}$

planarity of installation surface $\square 0,1$
 roughness of installation surface $\sqrt{Ra} 6,3$

Option F - Flat ribbon cable

Option R - Round cable

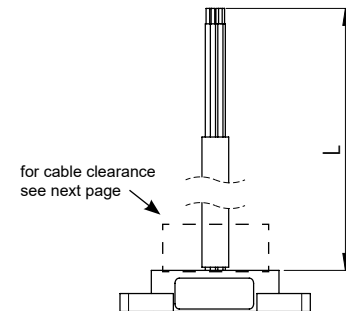
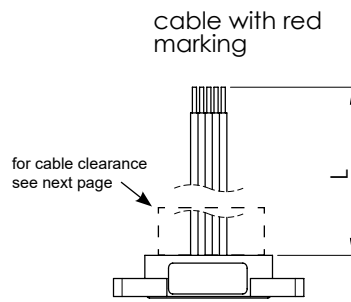

Table for parameter L see next page

Magnet thickness and distance from sensor surface (standard magnet only)

Electronics	Thickness T of the magnet	Mounting distance D
Analogue single turn not redundant, ETA25K, ETP25K, ETS25K (SPI only)	2 mm	1.00 +/- 0.15 mm
Analogue / Serial redundant, ETA25KX, ETS25KX	2.5 mm	0.50 +/- 0.15 mm
Incremental ET125K, Serial ETS25K (SSI only)	4 mm	0.20 +/- 0.15 mm
Analogue Multi/singleturn ETA25KPM	4 mm	0.20 +/- 0.15 mm

Angular error in dependency of the deviation of the magnet to the center axis

Deviation from the center axis	Angular error
0.50 mm	0.6°
0.75 mm	1.2°

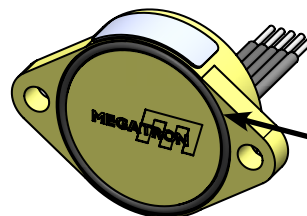

O-ring, part no. 133324
 DIN 3771-22x1-NBR 70

- for sealing between sensor front and installation surface,
- not included in delivery, please order separately

Important note:

The correct thickness T of the magnet, the mounting distance D and the positioning relative to the central axis of the kit encoder are crucial for its correct function.

Cable specs for option F (flat ribbon cable) and R (round control cable)						
Option	Standard cable length L	Number of single strands (depends on electronics)	Cable sheath Ø or width	Single strands cross section	Allowed tolerance (L)	Minimum bending radius
R	Standard 1000 mm	3	4.3 mm	AWG26	-20 mm to +50 mm	3 x D Ø (D = cable sheath diameter Ø)
		6	5.2 mm			
		8	5.6 mm			
		12	6 mm	AWG28		
F	150 mm	3 to 12	ca. 1.25 per strand	AWG26	-20 mm to +25 mm	-

Cables without cable shield

(*) Tolerances according IPC Association

Cable length tolerances – custom lengths	
Length L	Tolerance
≤ 0.3 m	+25 mm / -20 mm
> 0.3 m - 1.5 m	+50 mm / -20 mm
> 1.5 m - 3 m	+100 mm / -40 mm
> 3 m - 7.5 m	+150 mm / -60 mm

Cable harness length measured from sensor surface or soldering pad including connector.
Minimum cable length: 0.08 m (for round cable), 0.05 m for ribbon cable

Series	Electronics	Clearance parameters [mm]		
		A	B	C
ETP25K	PWM, single turn	6	8	15
ETA25K	Analogue, single turn	6	8	15
ETA25KPM	Analogue, programmable multiturn	6	14	15
ETA25KX	Analogue, redundant single turn	18	8	15
ETI25K	Incremental, single turn, A, B, Z	6	14	15
	Serial, single turn, SER (deprecated)	6	14	15
	Serial, single turn, SPI, SSI	9	14	15
ETS25KX	Serial, redundant, single turn (SPI)	18	12	20

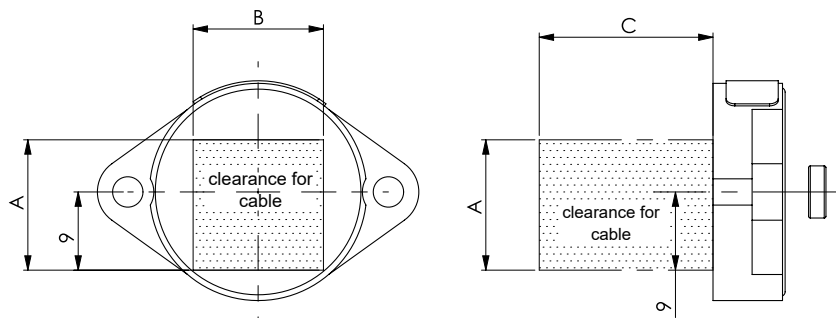

Signal definition for custom rotation angles

Custom angles <360°

When programming the electrical angle of rotation of <360°, the remaining non-effective range of rotation is divided equally into high and low.

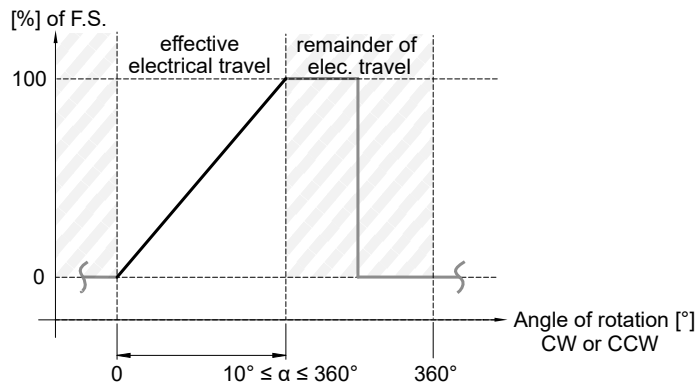

Mechanical and environmental data - ETx25K Family	
Mechanical angle of rotation 1.)	Endless
Lifetime 2.)	Mechanically unlimited
Max. operational speed	The maximum actuation speed is not limited mechanically. The maximum permissible actuation speed [rev./min] is calculated in relation to the resolution. For absolute encoders:
	$rev./min. (@max. resolution) = \frac{1}{2^{Resolution\ in\ Bit} * Update\ rate\ in\ s}} * 60s$
	For incremental encoders:
	$Max. rev./min. = \frac{Limit\ Frequency\ \frac{1}{s} * 60s}{Number\ of\ Pulses}$
Operating temperature range	-40..+85°C (fixed cable)
Storage temperature range	-40..+105°C
Protection grade front side (IEC 60529)	IP6
Protection grade rear side (IEC 60529)	IP67 (end of cable excluded) - standard with encapsulated electronics IP00 (end of cable excluded) - option without encapsulated electronics
Vibration (IEC 68-2-6, Test Fc)	±1.5 mm / 20 g / 10 bis 2000 Hz / 16 frequency cycles (3x4 h)
Mechanical shock (IEC 68-27, Test Ea)	50 g / 11 ms / halfsine (3x6 shocks)
Housing diameter / length	25 mm (dimensions of the mounting flange, height: 37 mm, width 25 mm)
Housing depth	8 mm
Shaft diameter	No limitation
Mass	Option F (0.15 m flat ribbon cable) approx. 15 g Option R (1.00 m round cable) approx. 40 g
Connection type	<ul style="list-style-type: none"> ▪ Flat ribbon cable (AWG26, 0.15 m with tinned cable endings) ▪ Round cable (AWG26, 1 m with tinned cable endings) ▪ Other connection types on request
Connection position	Axial
Sensor mounting	Flange, by means of two pieces of screws M3
Delivery content	Kit Encoder and Magnet. O-ring/gasket must be ordered separately (Screws for fastening the rotary encoder are not part of the scope of delivery)
Fastening torque (per screw or nut)	≤ 0.5 Nm
Housing material	Glass-fibre reinforced thermoplastic

1.) According IEC 60393

2.) Determined by climatic conditions according to IEC 68-1, para. 5.3.1 without load collectives

Immunity / Electrostatic Discharge	
EN 61000-4-3 RF sine wave	Class A
EN 61000-4-6 Conducted sine wave	Class A
EN 61000-4-8 Power frequency magnetic fields	Class A
EN 61000-4-2 ESD	Class B