

Series ETP25F – singleturn, PWM output, not redundant

Key features ETP25F:

- PWM signal output
- Frequency 244 Hz (constant)
- Pulse width (duty cycle) 10% (0°) to 90% (360°)
- Supply voltage: 5 VDC +/-10%



Electrical data ETP25F – singleturn, PWM output, not redundant

Effective electrical angle of rotation 1.)	$7^\circ \leq \alpha \leq 360^\circ$ (programmable ex works), $\pm 0.5^\circ$
Independent linearity (best straight line) 1.)	$\pm 0.4\%$ @ 360°
Absolute Linearity 1.)	$\pm 0.6\%$ @ 360°
Output signal	PWM (pulse width modulation)
Output signal voltage	5 V
Carrier frequency	244 Hz (constant)
Minimum duty cycle	10%, equal to app. 0.4 ms
Maximum duty cycle	90%, equal to app. 3.5 ms
Resolution	12 Bit
Supply voltage V_{SUP}	5 V $\pm 10\%$
Power consumption (no load)	≤ 10 mA
Output load	≥ 5 kOhm
Insulation voltage 1.)	1000 VAC @ 50 Hz, 1 min
Insulation resistance 1.)	2 MOhm @ 500 VDC, 1 min
MTTF (EN29500-2005-1)	1267a

1.) According to IEC 60393

Function description PWM signal output ETP25F

The ETP25F provides a constant carrier frequency with 244 Hz at the signal output, with HIGH and LOW signal levels which have a constant signal amplitude. A constant carrier frequency means a constant length of the period duration. The duty cycle and thus the pulse width changes in dependency of the rotating angle between 10% to 90% relative to the signal period. If the CW option is selected, the duty cycle increases clockwise when turning the shaft clockwise. If the CCW option is selected, the duty cycle decreases clockwise if the shaft is turned clockwise. Normally no signal conversion is required for further processing of the output signal, because many μ Controllers already have an input for PWM signals.

Cable and pin assignment

Function	Option F (flat ribbon)	Option R (round cable)
OUT	Lead 2	brown
VSUP	Lead 1 (red)	red
GND	Lead 3	black

For details on zero point definition and output programming see page 27.

Order Code ETP25F – singleturn, PWM output, not redundant									
Description	Selection: standard= black/bold , possible options= <i>grey/italic</i>								
Series	ETP25F								
Shaft diameter, shaft length: Shaft diameter \varnothing 6 mm, shaft length 15.6 mm <i>Shaft diameter \varnothing 6.35 mm, shaft length 15.6 mm</i> <i>Custom shaft dimensions [mm] $\varnothing \leq 6.35$ mm</i>	6x15,6 <i>6,35x15,6</i> <i>XxXX</i>								
Supply voltage / output signal: $V_{SUP}=5$ V (4.5...5.5 V) / OUT=5 V / 244 Hz / PWM 10-90%			5PWM						
Sense of rotation: (when looking at the shaft, from the front) Clockwise <i>Counterclockwise</i>				CW <i>CCW</i>					
Rotation angle in [°]: 360 <i>320</i> <i>270</i> <i>180</i> <i>90</i> <i>Custom rotation angle ($\geq 7^\circ$, positive integer)</i>					<i>360</i> <i>320</i> <i>270</i> <i>180</i> <i>90</i> <i>XXX</i>				
Operational Torque: Standard torque <i>Improved/medium torque</i>						- <i>MT</i>			
Shaft sealing: None <i>With shaft sealing</i>							- <i>D</i>		
Electrical connection, cable length: Flat ribbon cable, standard length 0.15 m <i>Flat ribbon cable with custom length [x,xx m]</i> Round cable, standard length 1 m <i>Round cable with custom length [x,xx m]</i>								F0,15 <i>FX,XX</i> R1,00 <i>RX,XX</i>	
Anti-rotation pin: Pin A <i>None (pin removed)</i>									A <i>-</i>

Order example ETP25F – singleturn, PWM output, not redundant									
Requirement: Shaft \varnothing 6.35 mm, shaft length 15.6 mm, VSUP=5 V / OUT=244 Hz, sense of rotation CW, rotation angle 360°, no shaft sealing, anti-rotation pin A, round cable 2 m									
Example for order code: ETP25F 6,35x15,6 5PWM CW360 R2,00A									

Drawing ETx25F Family

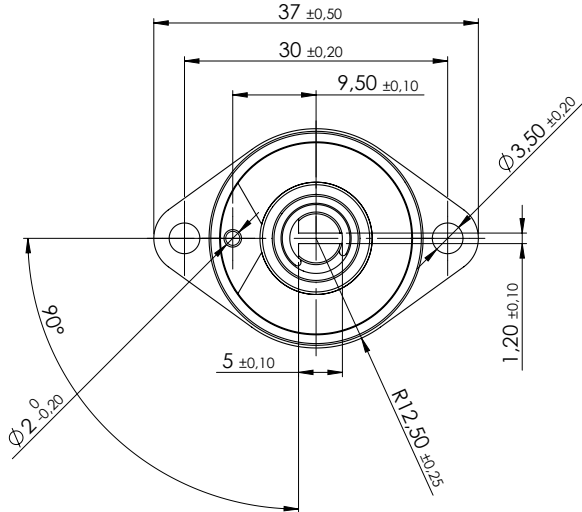

View shows 0° position

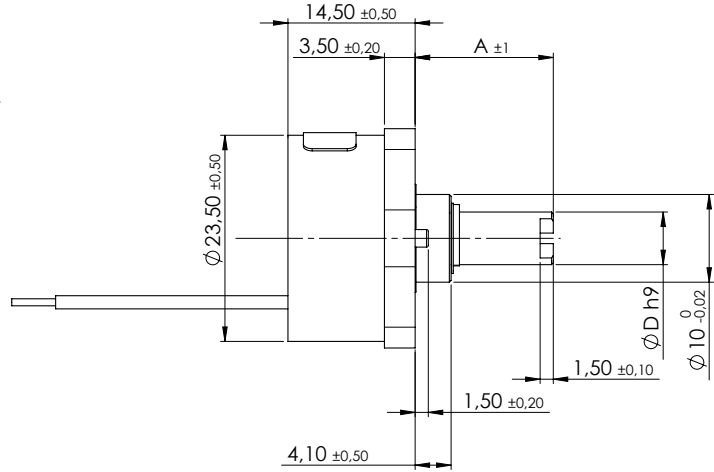

Standard shaft dimensions	
Shaft length A	15,6 mm
Shaft diameter D	6 mm

planarity of installation surface 0,1
 roughness of installation surface \sqrt{Ra} 6,3

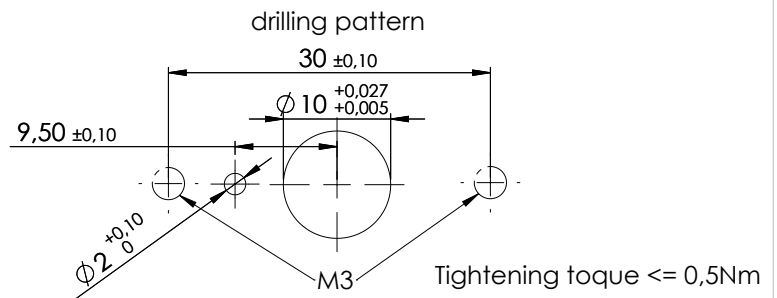

Option F - Flat ribbon cable

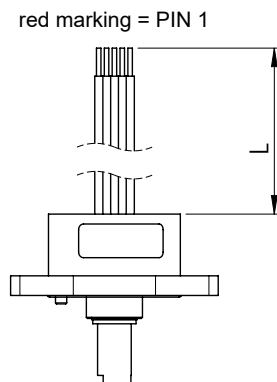

Option R - Round cable

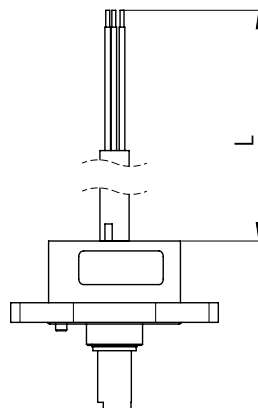

Standard shaft dimensions	
Shaft length A	15.6 +/- 1 mm
Shaft diameter D	6 h9 mm, 6.35 h9 mm
Shaft flattening (D-flat)	1 +/- 0.1 mm

All dimensions in mm

Cable specs for option F (flat ribbon cable) and R (round control cable)						
Option	Standard cable length L	Number of single strands (depends on electronics)	Cable sheath Ø or width	Single strands cross section	Allowed tolerance (L)	Minimum bending radius
R	Standard 1000 mm	3	4.3 mm	AWG26	-20 mm to +50 mm	3 x D Ø (D = cable sheath diameter Ø)
		6	5.2 mm			
		8	5.6 mm			
		12	6 mm	AWG28		
F	150 mm	3 to 12	ca. 1.25 per strand	AWG26	-20 mm to +25 mm	-

Cables without cable shield

(*) Tolerances according IPC Association

Cable length tolerances – custom lengths	
Length L	Tolerance
≤ 0.3 m	+25 mm / -20 mm
> 0.3 m - 1.5 m	+50 mm / -20 mm
> 1.5 m - 3 m	+100 mm / -40 mm
> 3 m - 7.5 m	+150 mm / -60 mm

Cable harness length measured from sensor surface or soldering pad including connector.
 Minimum cable length: 0.08 m (for round cable), 0.05 m for ribbon cable

Mechanical and environmental data, miscellaneous	
Mechanical angle of rotation 1.)	Endless
Lifetime 2.)	> 100 Mio. shaft rotation movements Option D: Sealing specified for $\geq 200\,000$ shaft rotation movements
Bearing	Sleeve bearing
Max. operational speed	100 rpm (< 1 min. 800 rpm)
Operational torque	$0.1 \leq M \leq 0.6$ Ncm (without shaft sealing) $0.3 \leq M \leq 1.3$ Ncm (@RT, 10 rpm) (with increased torque)
Operating temperature range	Standard: -40 to +85 °C (cable not moving)
Storage temperature range	Standard: -40 to +105 °C
Protection grade (IEC 60529) front side	<ul style="list-style-type: none"> ▪ IP40 standard ▪ IP55M (IP66S) with shaft sealing (option D)
Protection grade (IEC 60529) rear side	IP66 (cable ends excluded)
Vibration (DIN EN 60068-2-6)	± 1.5 mm / 30 g / 10 to 2000 Hz / 16 frequency cycles (3x4 h)
Shock (DIN EN 60068-2-27)	50 g / 11 ms / half sine (3x6 shocks)
Housing diameter	$\varnothing 23.5$ mm (dimensions of the mounting flange, height: 37 mm, width 25 mm)
Housing depth	14.5 mm
Shaft diameter	Standards: $\varnothing 6$ mm, $\varnothing 6.35$ mm Option: User defined shaft diameter [mm]
Max. radial load	1 N
Max. axial load	1 N
Mass (circa)	<ul style="list-style-type: none"> ▪ ca. 40 g (option R: cable, valid for 1 m only) ▪ ca. 23 g (option F: flat ribbon cable, valid for 15 cm only)
Connection type	<ul style="list-style-type: none"> ▪ Ribbon cable (option F) ▪ Cable (option R)
Connection position	Axial
Sensor mounting	Flange, by means of two screws M3 (not enclosed)
Fastening parts included in delivery	If option D is ordered an additional O-Ring is part of delivery as sealing between mounting panel and rotary encoder.
Fastening torque mounting nut	≤ 3 Nm
Material shaft	Stainless steel
Material housing	Plastic / Bronze

1.) According to IEC 60393

2.) Determined by climatic conditions according to IEC 68-1, para. 5.3.1 without load collectives

Immunity / Electrostatic Discharge	
EN 61000-4-3 RF sine wave	Class A
EN 61000-4-6 Conducted sine wave	Class A
EN 61000-4-8 Power frequency magnetic fields	Class A
EN 61000-4-2 ESD	Class B

Definition of the zero position / anti-rotation pin

Output at the zero point:

ETA25F (analogue outputs): Output signal 0% full scale (F. S.)
 ETP25F (PWM output): duty cycle 10% (10% duty cycle)
 ETS25F (serial output): Output signal 0% full scale (F. S.)
 ETI25F (incremental output): The index signal is output (Z)

Position of the zero position:

anti-rotation pin A	Zero position when shaft flattening faces anti-rotation pin A
---------------------	---

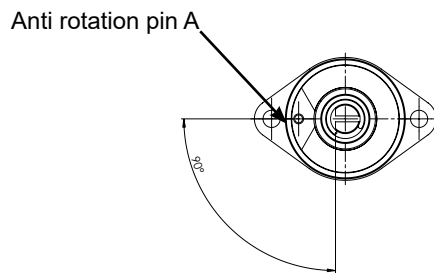

Signal definition for custom rotation angles

Custom angles <math><360^\circ</math>

When programming the electrical angle of rotation of <math><360^\circ</math>, the remaining non-effective range of rotation is divided equally into high and low.

