

## Series HTI36 - singleturn, incremental output

### Key features HTI36:

- Channels: A, B and index signal Z
- TTL or Open Collector electronics
- Maximum number of pulses per channel 1.024 (TTL), 20.000 pulses per revolution (option BZOC only)
- Option: ex works programmable number of pulses in pulse step width 1



## Electrical data HTI25K – singleturn, incremental output

Output Signal	TTL	Open Collector
Number of pulses	1 to 1024 ppr	1 to 20.000 ppr
Limit frequency	100 kHz	250 kHz
Switch-on delay	20 ms	6.3 ms
Supply voltage	5 VDC ±10%	4.8 to 42 V
Power consumption (no load)	≤ 15 mA	≤ 24 mA (for 5 V input)
Output load	≥ 5 kOhm	
Max. pull-up voltage	-	42 VDC
Max. pull-up current	-	600 mA
Insulation voltage 1.)	1000 VAC @ 50 Hz, 1 min	
Insulation resistance 1.)	2 MOhm @ 500 VDC, 1 min	
MTTF (SN29500-2005-1)	473a	1000a

## Output circuit HTI36 per channel

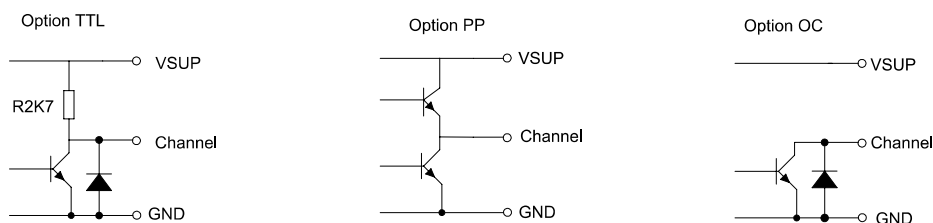

## Connector types M12 (R) HTI36 – pin numbering

### Type 2 (8 pole)

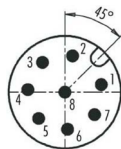

### Type 3 (12 pole, special versions only)



The orientation of the connector relative to the encoder housing is not defined and differs from one encoder to the next. When using angled connectors in combination with axial outlet, the orientation of the cable outlet is thus not defined.

If you need a defined orientation of the cable outlet, please choose our housings with radial cable outlet and use straight mating connectors.

Order Code HTI36 - solid or hollow shaft, singleturn, incremental signal output							
Description	Selection: standard= <b>black/bold</b> , possible options= <i>grey/italic</i>						
<b>Series HTI36</b>	<b>HTI36</b>						
<b>Shaft type:</b> <b>Solid shaft</b> <b>Hollow shaft with screw fixation</b> <i>Hollow shaft with clamp fixation</i>		<b>S</b> <b>H</b> <i>HK</i>					
<b>Shaft diameter, shaft length:</b> <b>Shaft diameter Ø 6 mm</b> <i>Shaft diameter Ø 8 mm</i> <i>Shaft diameter Ø 6.35 mm</i> <i>User-defined shaft diameter [mm]</i> <small>Ø ≤8 mm in connection with option S Ø ≤10 mm in connection with option H or HK Ø ≤12 mm exclusively in connection with option H</small>			<b>6</b> <i>8</i> <i>6,35</i> <i>X</i>				
<b>Multiplication symbol [x]:</b> <b>For solid shaft (S)</b> <b>For Hollow shaft H or HK</b>				<b>X</b> <i>-</i>			
<b>Visible shaft length:</b> <b>Shaft length 16.5 mm for solid shaft (S)</b> <b>shaft length for hollow shafts H or HK</b> <i>User-defined shaft length for solid shaft S [mm]</i>				<b>16,5</b> <i>-</i> <i>XX</i>			
<b>Number of pulses (pulses per revolution)</b> <i>100</i> <b>360</b> <i>512</i> <b>1024</b> <i>User-defined number of pulses</i>					<i>100</i> <b>360</b> <i>512</i> <b>1024</b> <i>XXXX</i>		
<b>Supply voltage / output signals:</b> <b>VSUP=5 V ± 10% / OUT=TTL A, B, Z</b> <b>VSUP=4.8 to 42 V / OUT=open collector A, B, Z</b>						<b>05BZTTL</b> <b>BZOC</b>	
<b>Shaft sealing:</b> <b>Without shaft sealing (IP65)</b> <i>With shaft sealing (IP67)</i>							<i>-</i> <i>D</i>
<b>Electrical connection, cable length, position:</b> <b>1 m round cable, axial</b> <b>1 m round cable, radial</b> <b>Plug M12, axial</b> <b>Connector M12, radial</b> <i>Round cable, customer-specific cable length [X,XX m], axial</i> <i>Round cable, customer-specific cable length [X,XX m], radial</i>							<b>PG</b> <b>PGR</b> <b>M12</b> <b>M12R</b> <i>PG X,XX</i> <i>PGR X,XX</i>

**Order example HTI36 - solid shaft, singleturn, incremental output**

**Requirements:**  
Solid shaft Ø 6.00 mm, Shaft length 16.5 mm, number of pulses 1024, VSUP=5 V/TTL output signal, no shaft sealing, round cable 1 m, cable outlet position axial (in dependency to the shaft)

**Example for order code:**  
HTI36 S 6x16,5 1024 05BZTTL PG

**Cable and pin assignment HTI36 – option PP, TTL, OC**

<b>Function:</b>	<b>Option PG(R)</b>	<b>Option M12(R)</b>
GND	black	PIN 1
VSUP	red	PIN 2
Z	yellow	PIN 3
B	orange	PIN 4
A	brown	PIN 5
-	green n/c	PIN 6 n/c
-	-	PIN 7 n/c
-	-	PIN 8 n/c

Signal details

Incremental signal output patterns:

A, B, Z (05BZTTL, 24BZPP)

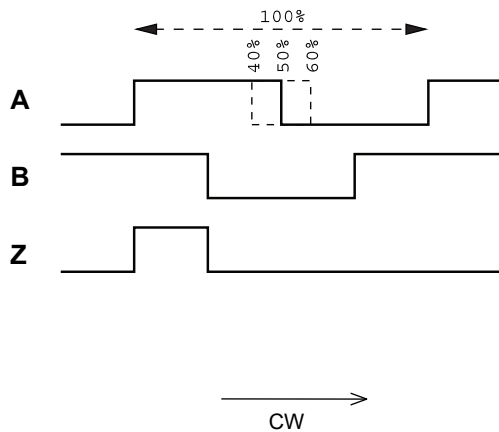

Option differential signal output (TTL N only)  
A, A/, B, B/, Z, Z/

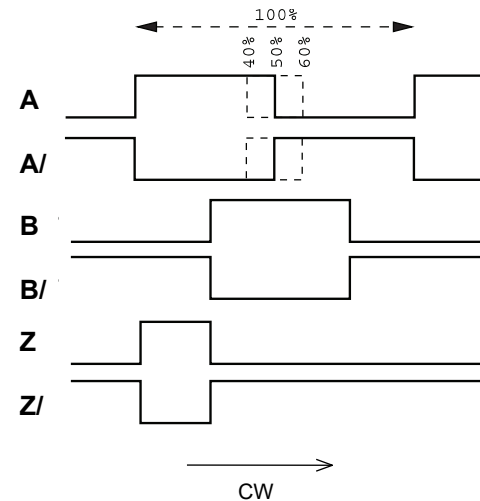

The percentage information describes the proportion of a pulse in dependency to the duration of one period

A, B, Z (Version BZOC)

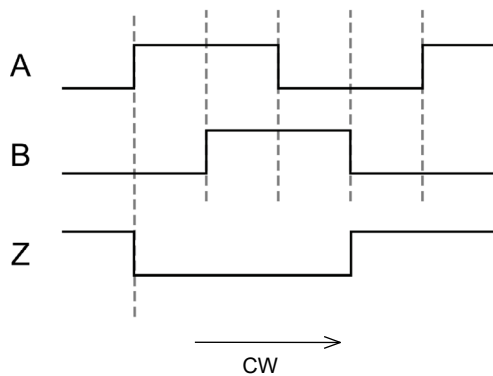

Drawings HTx36 S – solid shaft

HTx36 S (solid shaft), option M12 – M12 plug, axial orientation

Side view:

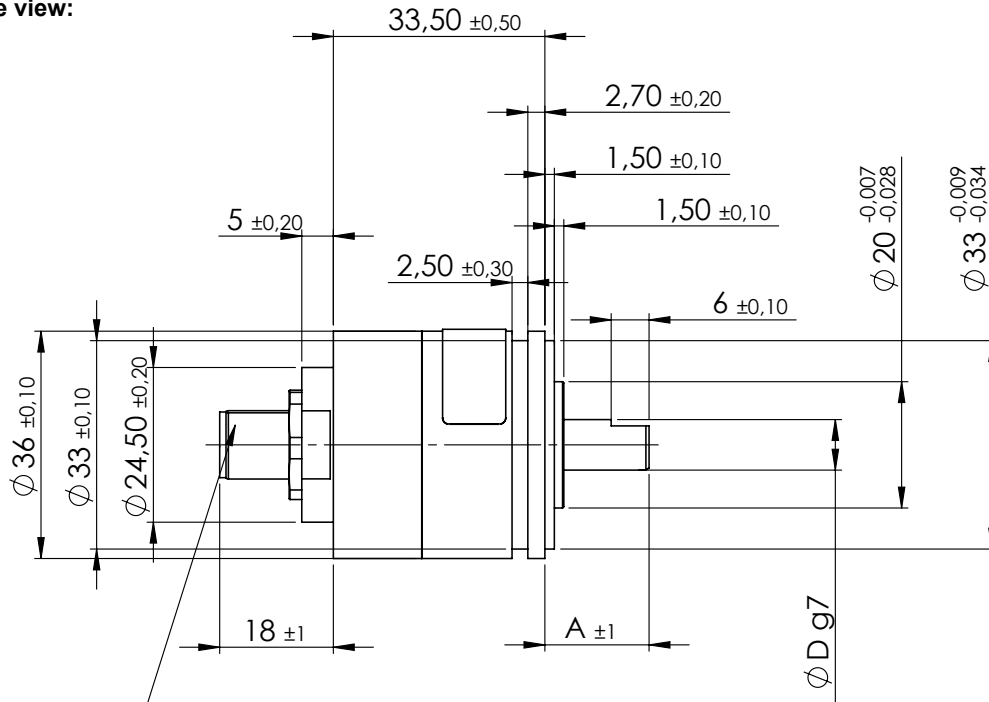

Binder male panel mount connector, range M12-A. 713 series or interoperable product

Standard shaft dimensions:  
HTx36 S with solid shaft

Shaft length A	16.5 mm
Shaft diameter D	6 mm 8 mm

Front view:

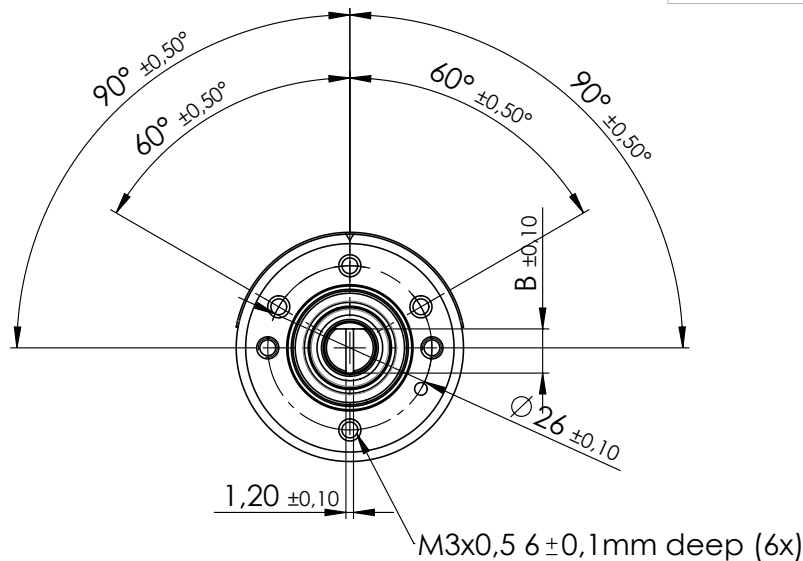

(\* Tolerances according IPC Association)

Drawings HTx36 S – solid shaft

HTx36 S (solid shaft), option M12R – M12 plug, radial orientation

Side view:

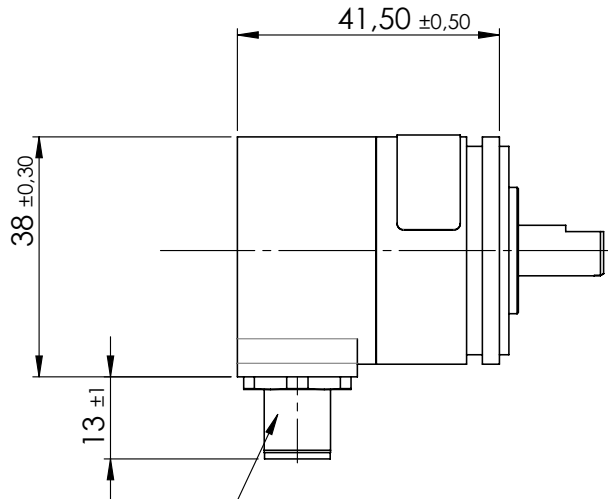

Front view:

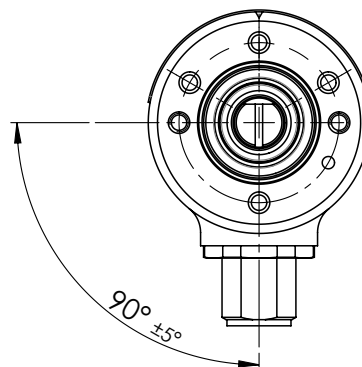

Binder male panel mount connector, range M12-A, 713 series or interoperable product

HTx36 S (solid shaft), option PG – cable gland, axial orientation incl. signal cable

Side view:

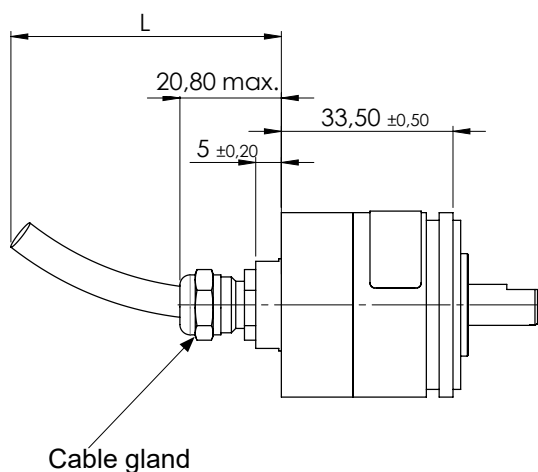

Front view:

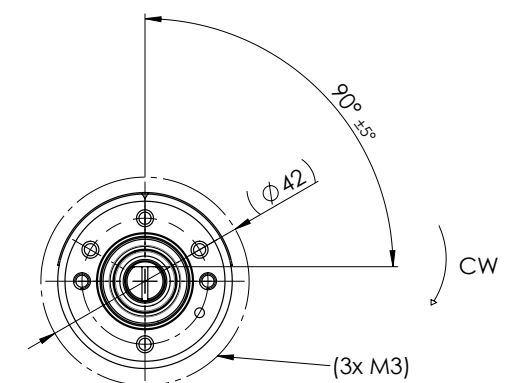

view shows 0° position

Drawings HTx36 S – solid shaft

HTx36 S option PG R – cable gland, radial orientation incl. signal cable

Front view:

Side view:

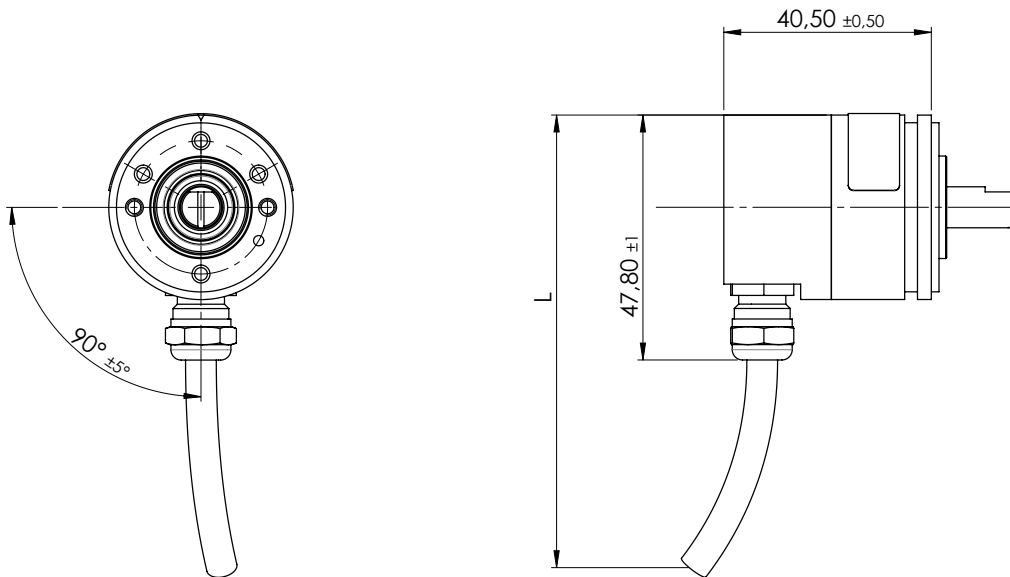

Ex works zero degree reference point (\*), sense of rotation:

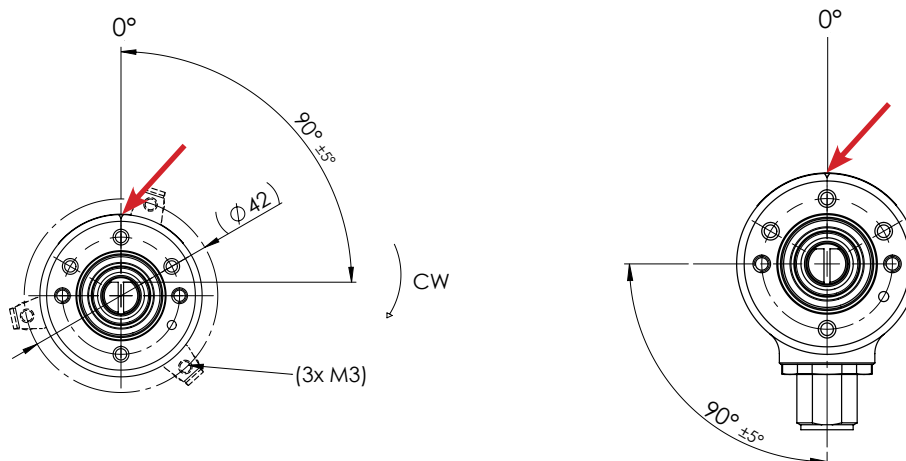

- (\*) The drawings above shows the zero degree (0°) reference correlation for HTx36 S rotary encoders
- 0° position: If the shaft flattening is facing the groove marked with the red arrow (see drawing above), then the output signal is 0% full-scale.

Drawings HTx36 H – hollow shaft (screw fixation)

HTx36 H (hollow shaft, grub screw fixation), option M12 – M12 plug, axial orientation

Side view:

Binder male panel mount connector, range M12-A, 713 series or interoperable product

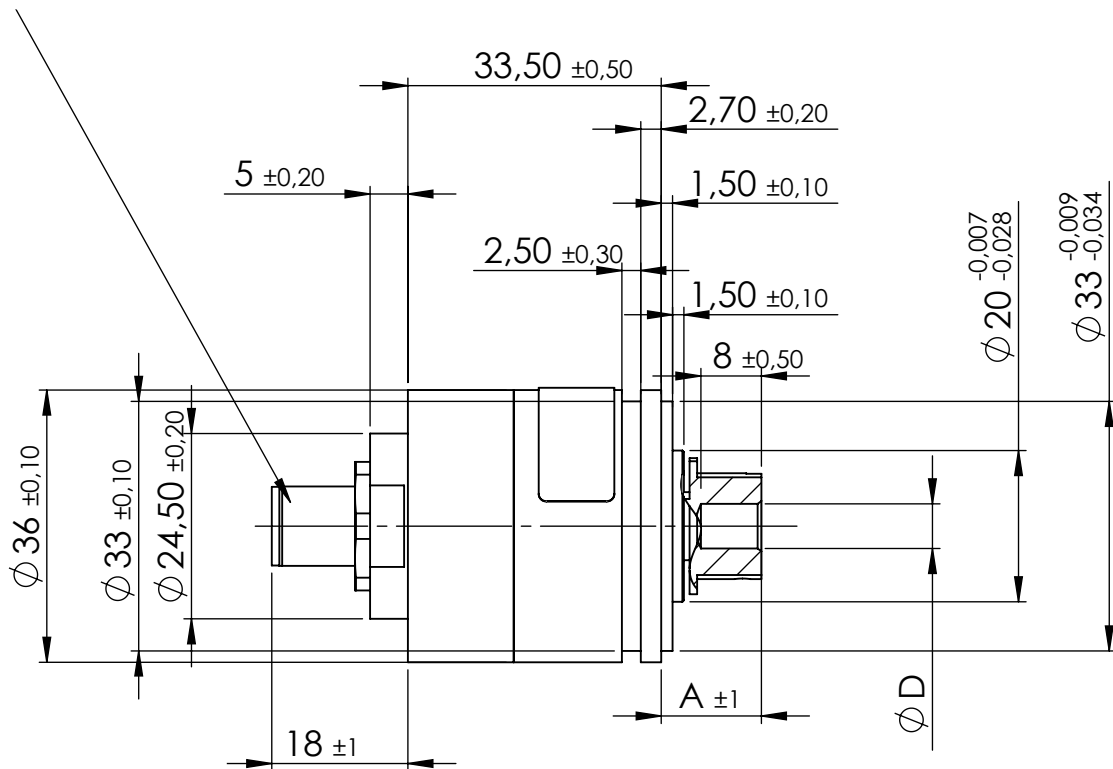

Front view:

View shows Product without Offset Bracket

Standard hollow shaft dimensions for HTx36 H with grub screw fixation

Hollow shaft length A	13.3 mm
Hollow shaft diameter D	6 mm 8 mm

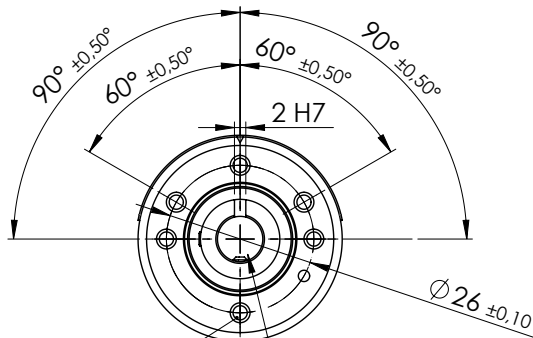

M3x0,5 6 ±0,1 mm deep (6x)

tightening torque of M2,5 screws SW1,3 ≤ 0,5Nm



Drawings HTx36 H – hollow shaft (screw fixation)

HTx36 H (hollow shaft screw fixation), option M12R – M12 plug, radial orientation

Side view:

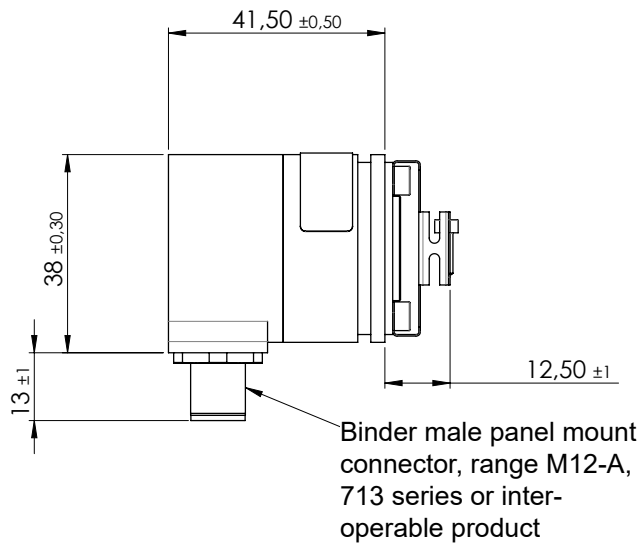

Front view:

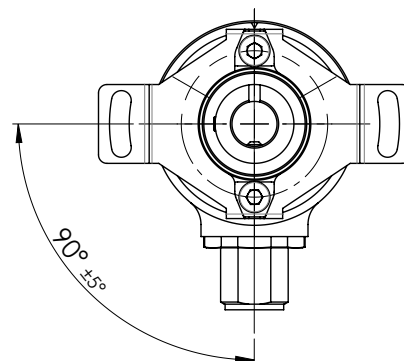

HTx36 H (hollow shaft, grub screw fixation), option PG – cable gland, axial orientation incl. signal cable

Side view:

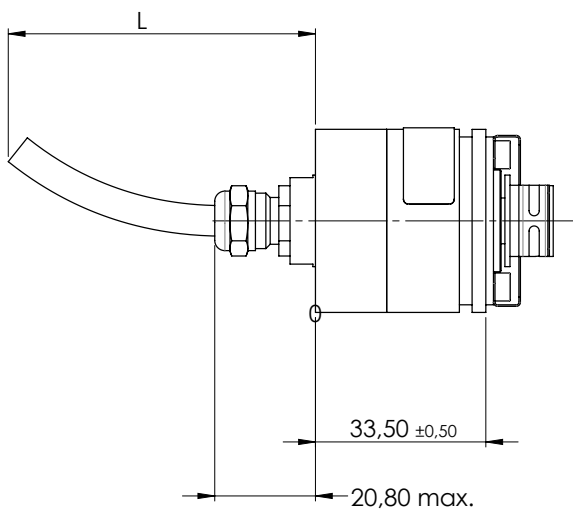

Front view:

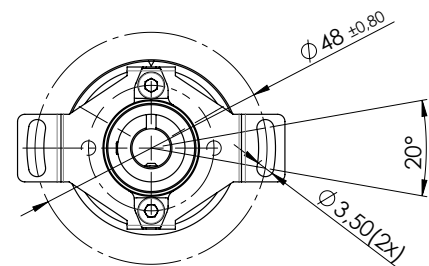

Drawings HTx36 H – hollow shaft (screw fixation)

HTx36 H (hollow shaft, grub screws fixation), option PG R – cable gland, radial orientation, incl. signal cable

Side view:

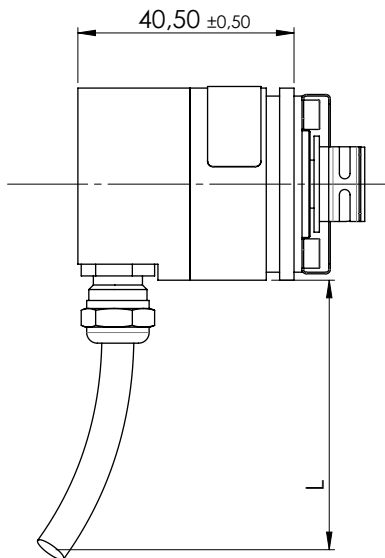

Front view:

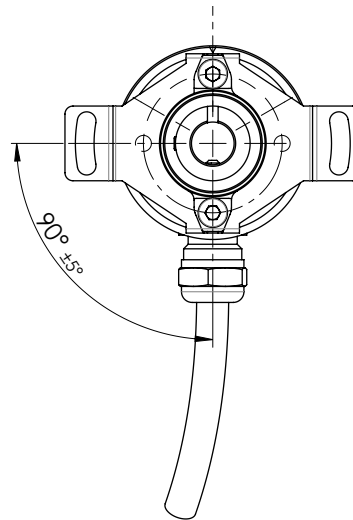

Ex works 0° position (\*), sense of rotation:

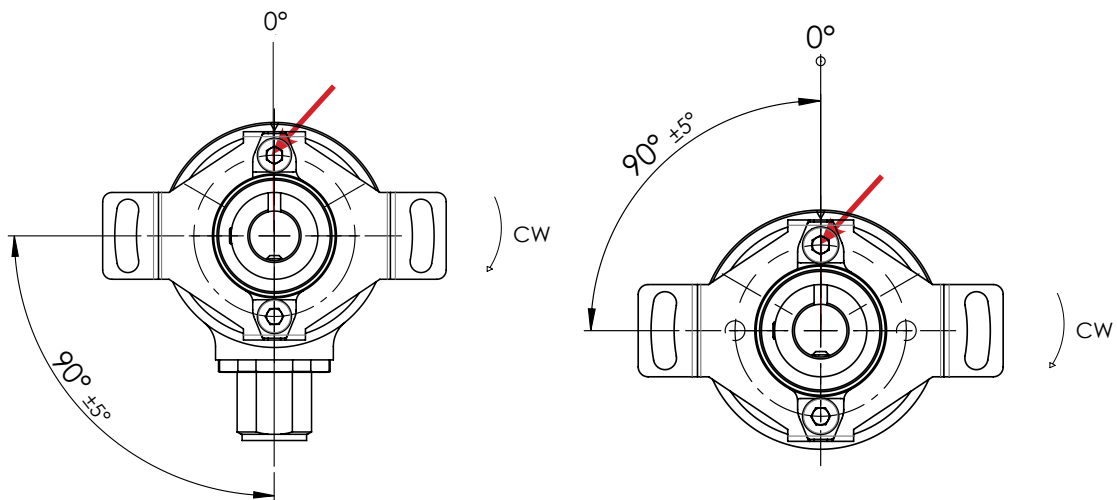

(\* ) The drawings above shows the zero degree (0°) reference  
 If the shaft slot is in a line with the groove in the encoder housing (groove is marked with a red arrow) then the output signal is 0% full-scale.

Drawings HTx36 HK – hollow shaft with clamp fixation

HTx36 HK (hollow shaft, clamp fixation), option M12 – M12 plug, axial orientation

Side view:

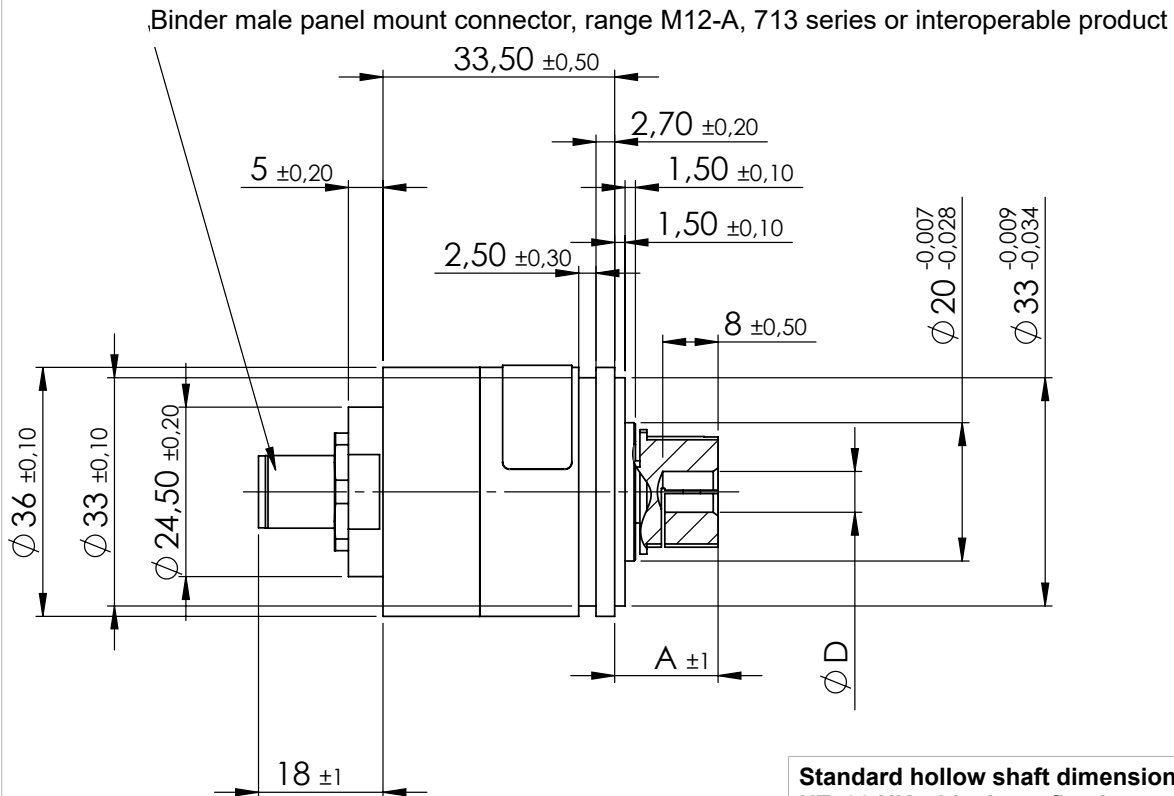

Standard hollow shaft dimensions for HTx36 HK with clamp fixation

Hollow shaft length A	15 mm
Hollow shaft diameter D	6 mm 8 mm

Front view:

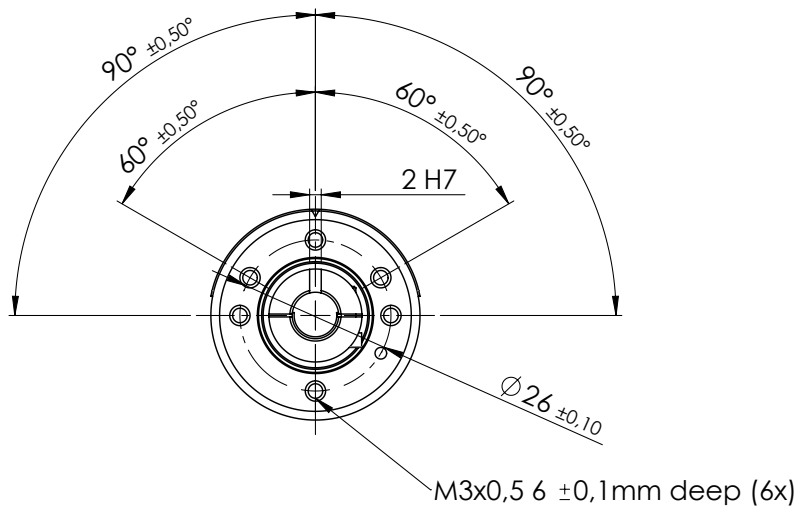

Drawings HTx36 HK – hollow shaft with clamp fixation

HTx36 HK hollow shaft, clamp fixation, option M12R – M12 plug, radial orientation

Side view:

Front view:

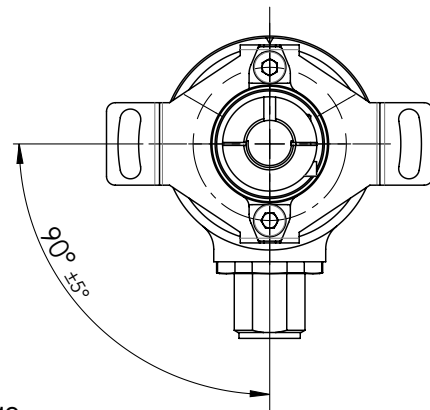
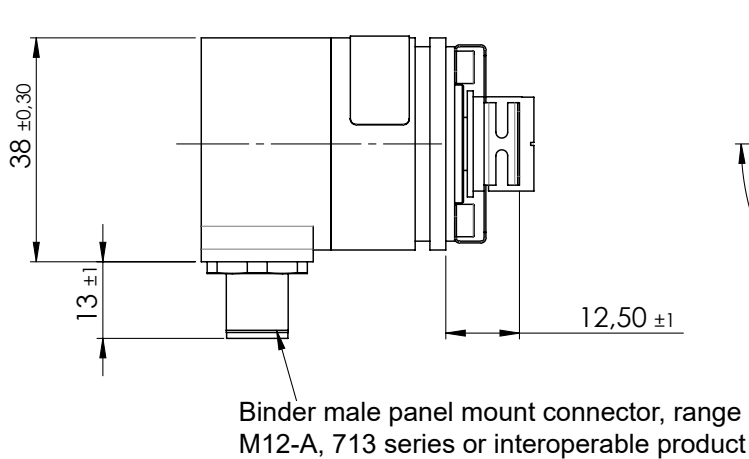

view shows connector orientation

HTx36 HK hollow shaft, clamp fixation, option PG – cable gland, axial orientation, incl. signal cable

Side view:

Front view:

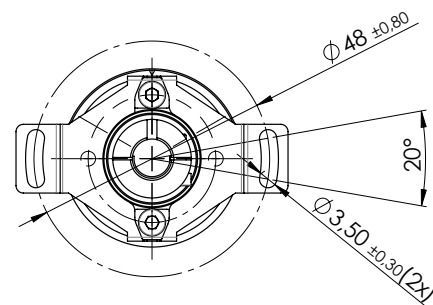
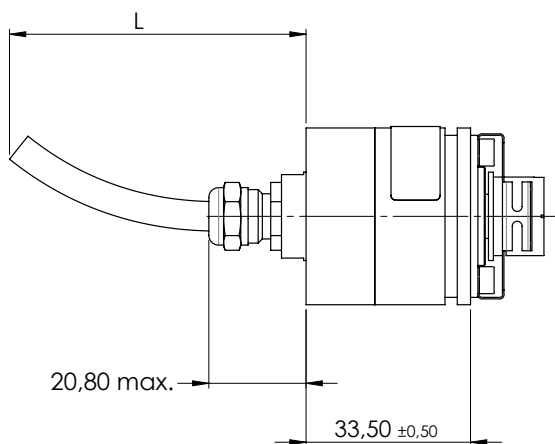

Drawings HTx36 HK – hollow shaft with clamp fixation

HTx36 HK with hollow shaft, clamp fixation), option PGR – cable gland, radial orientation, incl. signal cable

Side view:

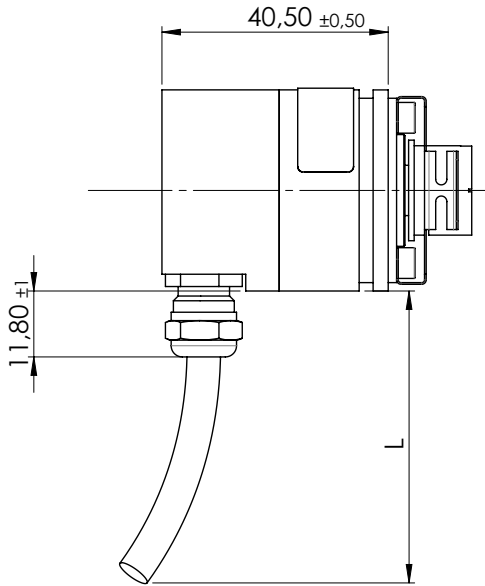

Front view:

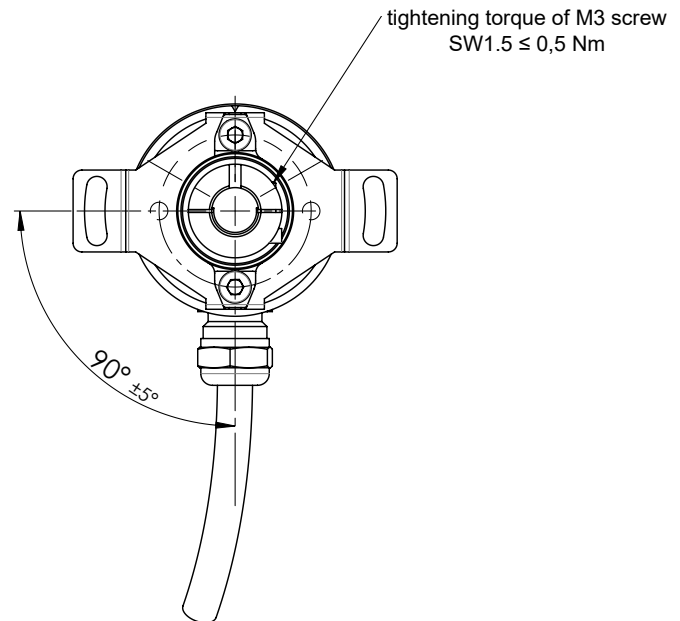

Ex works 0° position (\*), sense of rotation:

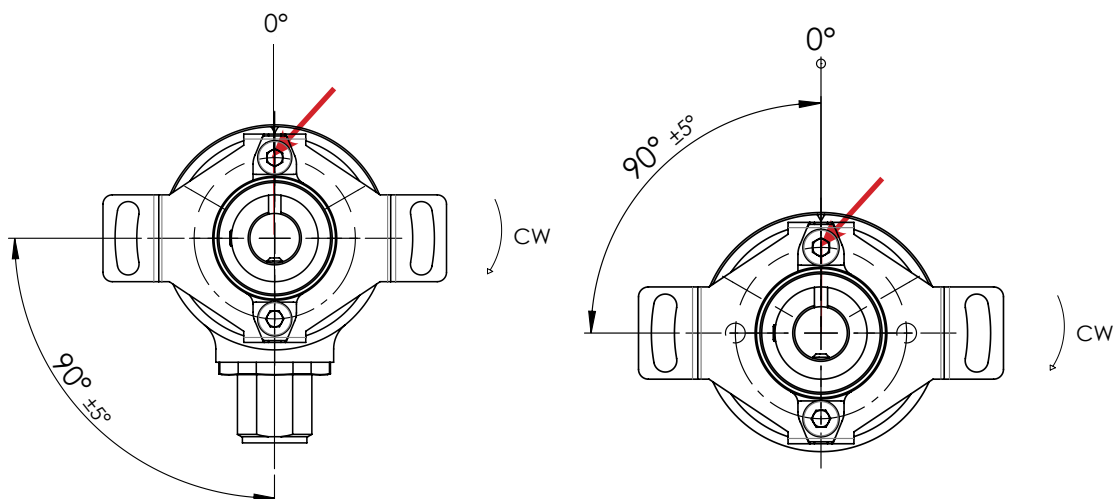

(\* ) The drawings above shows the zero degree (0°) position  
 If the shaft slot is in a line with the groove in the encoder housing (groove is marked with a red arrow) then the output signal is 0% full-scale.

Cable specs for option PG(R) (round control cable)						
Option	Standard cable length L	Number of single strands (depends on electronics)	Cable sheath Ø or width	Single strands cross section	Allowed tolerance (L)	Minimum bending radius
PG PGR	Standard 1000 mm	3		AWG26	-20 mm to +40 mm	10 x D Ø (D = cable sheath diameter Ø)
		6				
		8				
		10		AWG28		
		12				
Cables without cable shield						

(\*) Tolerances according IPC Association

Cable length tolerances – custom lengths	
Length L	Tolerance
≤ 0.3 m	+25 mm / -20 mm
> 0.3 m - 1.5 m	+40 mm / -20 mm
> 1.5 m - 3 m	+100 mm / -40 mm
> 3 m - 7.5 m	+150 mm / -60 mm
Wire harness length measured from sensor face including connector. Minimum cable length: 0.08 m (for round cable). Please contact us for lengths > 3 m regarding handling and packaging.	

<b>Mechanical and environmental data, miscellaneous – Family HTx36</b>	
Shaft type	Solid shaft (HTx36 S) or hollow shaft (HTx36 H)
Mechanical angle of rotation 1.)	Endless
Lifetime (HTx36 S – solid shaft encoders) 2.)	@100 % of max. permissible radial shaft load >1.4x10E8 shaft revolutions @80 % of max. permissible radial shaft load >2x10E9 shaft revolution @20 % of max. permissible radial shaft load >1.7x10E10 shaft revolutions For option D (shaft sealing), the denseness is up to 1E6 shaft revolutions ensured
Bearing	2 pcs. groove ball bearings type 2RS
Max. operational speed (with shaft sealing)	12.000 rpm
Operational torque: (@ room temperature and 10 rev/min)	Solid shaft: ▪ Standard IP65: ≤ 0.3 Ncm ▪ With option D IP67: ≤ 2 Ncm Hollow shaft: ▪ Standard IP65: ≤ 0.5 Ncm ▪ With option D IP67: ≤ 2 Ncm
Operating temperature range	Option M12 (plug) ▪ -30 to +85°C Option PG (cable gland incl. cable) ▪ -30 to +85°C cable fixed ▪ -10 to +85°C cable in movement
Storage temperature range	-30 to +105 °C
Protection grade (IEC 60529) front side	From shaft side: ▪ Standard IP65 ▪ With option D IP67
Protection grade (IEC 60529) rear side	IP68 (cable ends excluded)
Vibration (DIN EN 60068-2-6)	±1.5 mm / 30 g / 10 to 2000 Hz / 16 frequency cycles (3x4 h)
Shock (DIN EN 60068-2-27)	100 g / 6 ms / half sine (3x6 shocks)
Housing diameter	Ø 36 mm
Housing depth	In dependency to the electrical connection position ▪ axial 33.5 mm ▪ radial 40.5 mm
Shaft diameter	Shaft diameter solid shaft: Standard: shaft diameter Ø 6 mm, Ø 8 mm Shaft diameter Ø 6.35 mm Option User-defined shaft diameter [mm] Ø ≤8 mm in connection with option S Ø ≤10 mm in connection with option H or HK Ø ≤12 mm exclusively in connection with option HK
Max. radial load (HTx36E S)	80 N (load point 80% in dependency to the visible standard shaft length)
Max. axial load	50 N (axial application of force onto the shaft end)
Mass (circa)	HTx36 with Plug M12(R) and: ▪ Solid shaft: axial 98 g, radial 90 g ▪ Hollow shaft: axial 102 g, radial 104 g HTx36 with cable gland and 1 m signal cable PG(R) and: ▪ Solid shaft: axial 133 g, radial 123 g ▪ Hollow shaft, axial 140 g, radial 133 g

1.) According IEC 60393

2.) Determined by climatic conditions according to IEC 68-1, para. 5.3.1 without load collectives

**Mechanical and environmental data, miscellaneous – Family HTx36**

Connection type	Standard: <ul style="list-style-type: none"> <li>▪ Cable gland stainless steel M12, axial, shielded round cable, 1 m, AWG26, PVC sheath, cable endings tinned</li> </ul> Option: <ul style="list-style-type: none"> <li>▪ Plug M12, axial or radial</li> </ul>
Connection position	Axial or radial
Sensor mounting	Sensor mounting possibilities for solid shaft rotary encoders HTx36 S: <ul style="list-style-type: none"> <li>▪ Via threaded holes integrated in the sensors head by use of stainless steel screws M3x0.5</li> <li>▪ Via synchro flange with optional available servo mount fixing nails SFN1 incl. screws M3 x 0.5 from MEGATRON</li> </ul> Sensor mounting for hollow shaft rotary encoders HTx36 H(K): <ul style="list-style-type: none"> <li>▪ Using the ex work mounted torque bracket on the rotary encoder (spring plate) by means of 2 pcs of M3 screws</li> </ul>
Fastening parts included in delivery	None <ul style="list-style-type: none"> <li>▪ For fastening the rotary encoder by means of servo mount fixing nails SFN1 – available from MEGATRON as accessory</li> <li>▪ For options M12 (R), the M12 plug is not part of the scope of delivery. M12 plugs also incl. signal cable available as accessory from MEGATRON</li> </ul>
Fastening torque per screw for fastening of the rotary encoder	$\leq 0.6 \text{ Nm}$ (M3 screw) For screw securing, the use of a medium-strength thread securing adhesive is recommended
Maximum tightening torque for grub screw for fixation of the shaft, only HTx36 H	$\leq 0.5 \text{ Nm}$ (wrench size M2.5 grub screw)
Maximum tightening torque for grub screw for fixation of the shaft, only HTx36 HK	$\leq 0.5 \text{ Nm}$ (wrench size M1.5 grub screw)
Material shaft	Stainless steel
Material housing	Aluminium
Material cable gland M12	Stainless steel

**Immunity / Electrostatic Discharge / REACH / RoHS**

EN 61000-4-3 RF sine wave	Class A
EN 61000-4-6 Conducted sine wave	Class A
EN 61000-4-8 Power frequency magnetic fields	Class A
EN 61000-4-2 ESD	Class B
REACH Regulation (EC) 1907/2006 including the SVHC list	
RoHS Directive 2011/65/EU	