

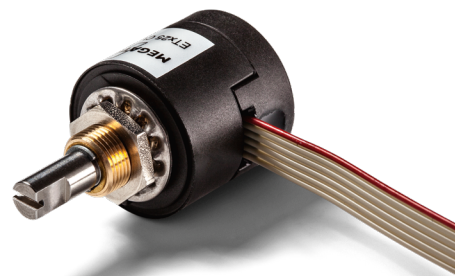

**EZA25PM**  
(round) control cable



**EZA25PM**  
flat ribbon cable

### Key features

- True-Power-On: Rotation of the shaft in a powerless state without loss of angular information.
- Battery-free and gearless
- Teach-in function for setting the output (start/end/center values)
- Measuring range up to max. 14,400° (40 shaft revolutions), factory setting 10 revolutions (3,600°).
- Ø25 mm housing made of glass fibre reinforced thermoplastic
- Magnetic measurement value acquisition, AMR and GMR sensor technology
- Digital signal processing
- Metal sleeve bearing > 100 million shaft revolutions
- Ø6 mm stainless steel shaft
- Sealing up to IP55M (IP66S with sealing option)
- Operating temperature -40°C to 85°C
- Electrical connection: 1 m round cable, 0.15 m ribbon cable
- Customised variants possible (factory programming, cable assemblies)

### Applications

- Determination of gear positions without reference run (servo motors, conveyor technology, drives, machine tools, slewing gears, telescopic arms)
- Cable winches
- Lifts
- As a panel encoder for manual input

#### Electrical data EZA25PM – Multiturn, True Power On, with teach-in function

|  |  |              |            |
|--|--|--------------|------------|
| Mechanical angle of rotation             | 0 to 14400° (max. 40 revolutions), no mechanical stop<br><small>Caution: Overturning beyond this range must be prevented, even when the encoder is without supply.</small> |              |            |
| Electrically effective angle of rotation | 3600° ex works, max. 14400° possible<br>The starting point, end point and direction of rotation can be parameterized by the user.  |              |            |
| Independent linearity                    | ±0.6% @ 360° / ±0.06% @ 3600°  |              |            |
| Load resistance                          | > 1 kΩ*  |              | 250 Ω      |
| Update rate                              | 5 ms   |              |            |
| Output signals                           | 0 to 5 V   | 0 to 10 V    | 4 to 20 mA |
| Resolution at output (DAC)               | 12 Bit   |              |            |
| Output voltage                           | 5.1 to 28 V  | 10.1 to 28 V | 12 to 28 V |
| Reverse polarity protection              | yes  |              |            |
| Short-circuit protection                 | yes  |              |            |
| Insulation voltage                       | 1000 VAC @ 50 Hz, 1 min  |              |            |
| Insulation resistance                    | 2 MOhm @ 500 VDC, 1 min  |              |            |

| Order Code EZA25PM – multi/singleturn, analogue output, not redundant  |   |  |  |  |   |  |               |
|--|---|--|--|--|---|--|---------------|
| Description  | Selection: standard= <b>black/bold</b> , possible options= <i>grey/italic</i> |  |  |  |   |  |               |
| <b>Series</b>  | <b>EZA25PM</b>  |  |  |  |   |  |               |
| <b>Shaft diameter, shaft length:</b><br>Shaft diameter Ø 6 mm, shaft length 22 mm<br><i>Shaft diameter Ø 6.35 mm, shaft length 22 mm</i><br><i>Custom shaft dimensions [mm] Ø ≤ 6.35 mm</i>  |   | <b>6x22</b><br><i>6,35x22</i><br><i>XxXX</i> |  |  |   |  |               |
| <b>Supply voltage / output signal:</b><br>VSUP=24 V (10.1 to 28 V) / OUT = 0 to 10 V<br>VSUP=24 V (5 to 28 V) / OUT = 4 to 20 mA *<br>VSUP=24 V (5.1 to 28 V) / OUT = 0 to 5 V *   |   |  |  |  | <b>2410</b><br><b>2442</b><br><b>2405</b> |  |               |
| <b>Operational Torque:</b><br>Standard torque<br><i>Improved/medium torque</i>   |   |  |  |  | -<br><i>MT</i>                            |  |               |
| <b>Shaft sealing:</b><br>None<br><i>With shaft sealing</i>   |   |  |  |  | -<br><i>D</i>                             |  |               |
| <b>Electrical connection, cable length:</b><br><i>Flat ribbon cable, standard length 0.15 m</i><br><i>Flat ribbon cable with custom length [x.xx m]</i><br><b>Round cable, standard length 1 m</b><br><i>Round cable with custom length [x.xx m]</i> |   |  |  |  |   | <i>F0,15</i><br><i>FX,XX</i><br><b>R1,00</b><br><i>RX,XX</i> |               |
| <b>Anti-rotation pin, zero point definition:</b><br>Pin A<br><i>None (pins removed) (no zero point definition possible)</i>  |   |  |  |  |   |  | <b>A</b><br>- |

\* Custom start and end values are available for project quantities via firmware adjustment e.g., 0.25–4.75 V or 1–10 V. Please contact us.

**Order example EZA25PM**
**Requirement:**

Shaft Ø 6.00 mm, shaft length 22 mm, VSUP=24 V / OUT=0 to 5 V, sense of rotation CW, rotation angle ex works 3600° (can be programmed by customer), no shaft sealing, flat ribbon cable 1.00 m, anti-rotation pin A

**Example for order code:**

EZA25PM 6x22 2405 R1,00A

**Cable and pin assignment**

| Function | Option F (flat ribbon cable) | Option R (round cable) |
|----------|------------------------------|------------------------|
| GND      | Strand 1 (red)               | black                  |
| OUT      | Strand 2                     | brown                  |
| VSUP     | Strand 3                     | red                    |
| TEACH-IN | Strand 4                     | orange                 |
| SW1      | Strand 5                     | yellow                 |
| SW2      | Strand 6                     | green                  |

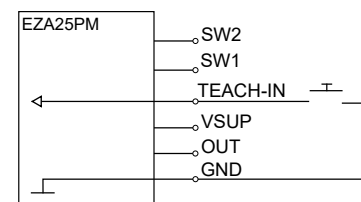

**Signal output function**

The rotary encoder counts internally up to a maximum of 46 revolutions, regardless of whether a power supply is available. However, if this range is exceeded (< 0) or exceeded (> 46), the rotary encoder can no longer count up or down and an error occurs. For programming (teach-in), a window of 40 revolutions can be used to set application-specific start and end points (or midpoints) of the output signal (e.g. 0 to 10 V). The rotary encoder delivers a signal of 0 to 5 V, 0 to 10 V or 4 to 20 mA (0 to 100% F.S./full scale) for a range of 10 revolutions ex works. This effective electrical angle of rotation of 3600° is achieved in the range of 18-28 revolutions:

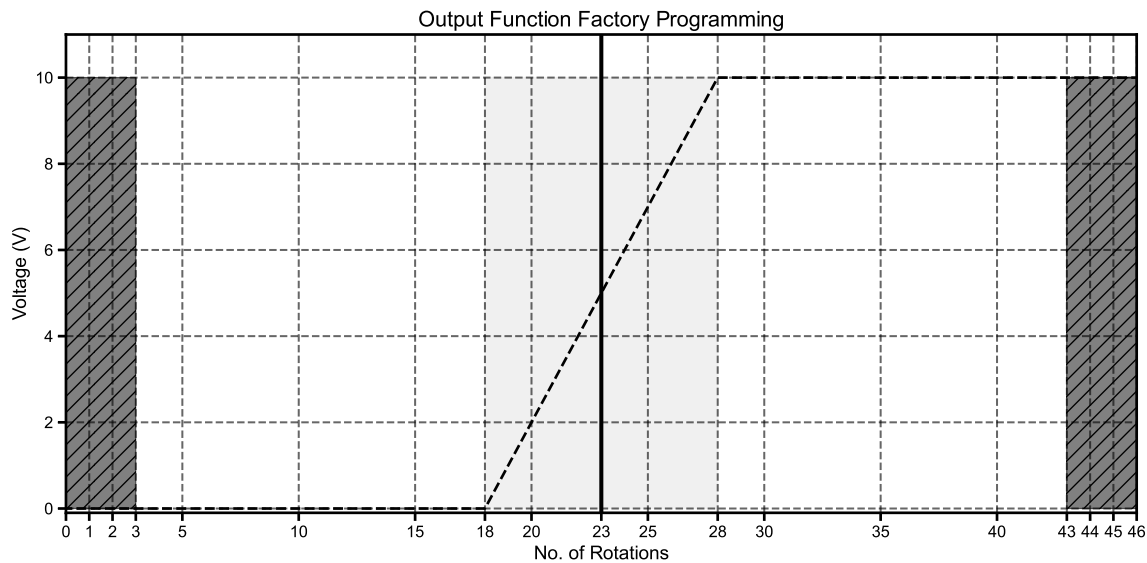

In its factory default state, the shaft is centered with the flat side facing the anti-rotation pin at 5 revolutions (2.5 V or 5 V, or 12 mA). Other start and end values (as well as the center position value) can be set via wire 4 / orange. Parameterization is performed via a low-active teach-in input; that is, the teach-in function is activated by applying a low level (ground) to the teach-in pin. The number of pulses is then evaluated.

| Number of pulses on strand 4 (Teach-In) | Function | Description  |
|---|----------|--|
| 2                                       | START    | Sets the current point as the lower scaling point (starting value) to 0 V / 4 mA, thus shifting the stop point as well (10 revolutions standard).          |
| 3                                       | STOP/END | Sets the current point as the upper scaling point (end value), i.e., to the maximum value of the output (5 V / 10 V / 20 mA)                               |
| 4                                       | CENTER   | Sets the current point to the 50% value of the output (2.5 V / 5 V / 12 mA) by shifting the start- and endvalues, provided it is mechanically permissible. |
| 5                                       | DIR      | Swaps direction CW/CCW, (start-/end value exchanged)   |
| 6                                       | RESET    | Resets the curve (zero/center point will be within +/-180° relative to shaft-flat)   |

The teach-in input is debounced with 10 ms. The pulse frequency is < 100 Hz. If the next pulse does not occur within 500 ms, the button count value is evaluated and reset to 0, i.e. the pulses must not have a pause of more than half a second.



**Avoid magnetic interference fields**

The encoders operate using magnetic measurement and do not have magnetic shielding. The encoder may be subject to interference. In the presence of strong interference fields, the multiturn sensor may enter a permanent error state. Interference fields should therefore be avoided.

Drilling pattern

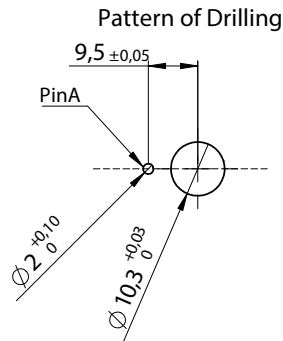

Pin A can be selected as the anti-rotation pin. If this is not desired, it can simply be cut off.

Drawings ETx25

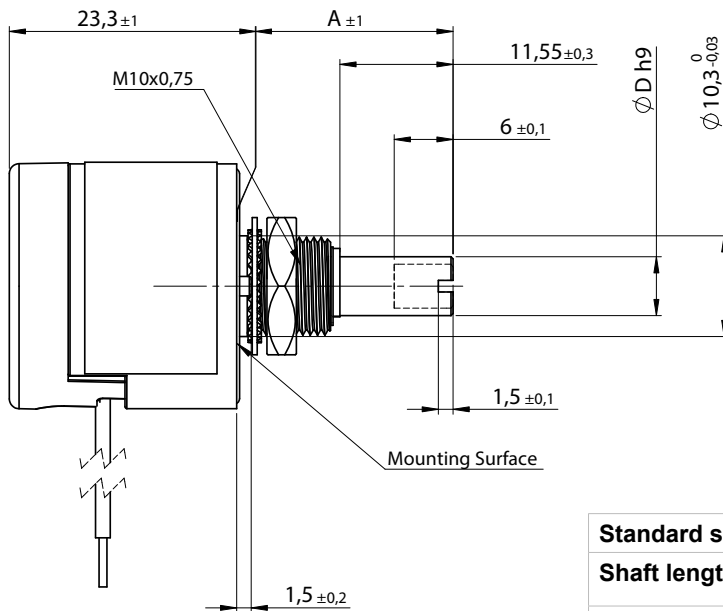

| Standard shaft dimensions |                     |
|---------------------------|---------------------|
| Shaft length A            | 22 +/- 1 mm         |
| Shaft diameter D          | 6 h9 mm, 6.35 h9 mm |
| Shaft flattening (D-flat) | 6 +/- 0.1 mm        |

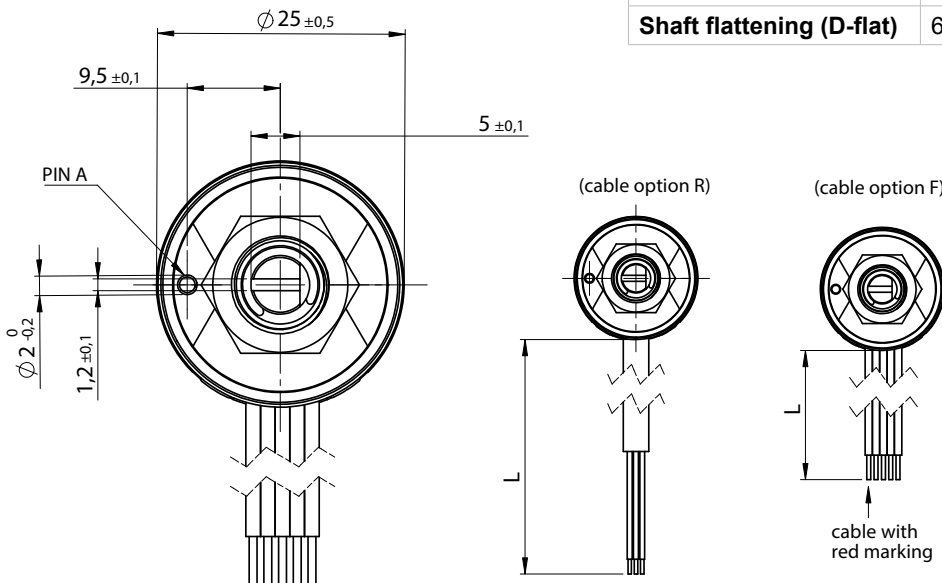

All dimensions in mm

**Definition of shaft position ex works**

When delivered, the encoder is set to 5 revolutions / 1800°. The shaft flattening points in the direction of the pin.

Contact us for information about alignment incl. tolerance.

**Cable specs for option F (flat ribbon cable) and R (round control cable)**

| Option | Standard cable length L | Number of single strands (depends on electronics) | Cable sheath Ø or width | Single strands cross section | Allowed tolerance (L) | Minimum bending radius                   |
|--------|-------------------------|---|-------------------------|------------------------------|-----------------------|--|
| R      | Standard 1000 mm        | 3   | 4.3 mm                  | AWG26                        | -20 mm to +50 mm      | 3 x D Ø<br>(D = cable sheath diameter Ø) |
|        |                         | 6 (Standard)                                      | 5.2 mm                  |                              |                       |  |
| F      | 150 mm                  | 3 to 6<br>(6 is standard)                         | ca. 1.25 per strand     | AWG26                        | -20 mm to +25 mm      | -  |

Cables without cable shield

**Cable length tolerances – custom lengths**

| Length L        | Tolerance        |
|-----------------|------------------|
| ≤ 0.3 m         | +25 mm / -20 mm  |
| > 0.3 m - 1.5 m | +50 mm / -20 mm  |
| > 1.5 m - 3 m   | +100 mm / -40 mm |
| > 3 m - 7.5 m   | +150 mm / -60 mm |

**Cable harness length measured from sensor surface or soldering pad including connector.  
Minimum cable length: 0.08 m (for round cable), 0.05 m for ribbon cable**

(\*) Tolerances according IPC Association

**Do not turn the sensors by hand before commissioning**



The encoders feature a 'True Power-On' function. This means that the electronics detect and store the number of revolutions, even when the power is off. However, if the encoder is accidentally rotated, it will lose its factory default setting (centre position within the rotation range). This can cause problems during commissioning. The physically accessible rotation range is limited to a maximum of <46 (or minimum >0) and must not be exceeded. It is not possible to reset the internal revolution counter electronically; however, it can be turned back to the starting point.

| Mechanical and environmental data, miscellaneous |  |
|--|--|
| Lifetime 1.)                                     | > 100 Mio. shaft rotation movements<br>Option D: Sealing of the shaft is working up to 200 000 shaft rotation movements                              |
| Bearing  | Sleeve bearing   |
| Max. operational speed                           | 100 rpm (< 1 min. 800 rpm)   |
| Operational torque                               | 0.1 ≤ M ≤ 0.6 Ncm (without shaft sealing)<br>0.3 ≤ M ≤ 1.3 Ncm (@RT, 10 rpm) (with increased torque)   |
| Operating temperature range                      | Standard: -40°C to +85°C (cable installed fixed)   |
| Storage temperature range                        | Standard: -40°C to +105°C  |
| Protection grade (IEC 60529) front side          | From shaft side:<br>▪ IP40 standard<br>▪ IP55M (IP66S) with shaft sealing (option D)   |
| Protection grade (IEC 60529) rear side           | IP66 flat ribbon and round signal cable (cable ends excluded)  |
| Vibration (DIN EN 60068-2-6)                     | ±1.5 mm / 30 g / 10 to 2000 Hz / 16 frequency cycles (3x4 h)   |
| Shock (DIN EN 60068-2-27)                        | 100 g / 6 ms / half sine (3x6 shocks)  |
| Housing diameter                                 | Ø 25 mm  |
| Housing depth                                    | see drawings   |
| Shaft diameter                                   | Standards: Ø 6 mm, Ø 6.35 mm<br>Option: User-defined shaft diameter [mm]   |
| Max. radial load                                 | 1 N  |
| Max. axial load                                  | 1 N  |
| Mass (circa)                                     | ▪ ca. 60 g (option R: cable, valid for 1 m only)<br>▪ ca. 32 g (option F: flat ribbon cable, valid for 15 cm only)                                   |
| Connection type                                  | ▪ Ribbon cable (option F)<br>▪ Cable (option R)  |
| Connection position                              | Radial   |
| Sensor mounting                                  | Bushing via M10 x 0,75   |
| Fastening parts included in delivery             | Hex nut and tooth washer, if option D is ordered then an additional O-Ring is part of delivery as sealing between mounting panel and rotary encoder. |
| Fastening torque mounting nut                    | ≤ 3 Nm   |
| Material shaft                                   | Stainless steel  |
| Material housing                                 | Plastic / Bronze   |

1.) Determined by climatic conditions according to IEC 68-1, para. 5.3.1 without load collectives

| Immunity / Electrostatic Discharge           |         |
|--|---------|
| EN 61000-4-3 RF sine wave                    | Class A |
| EN 61000-4-6 Conducted sine wave             | Class A |
| EN 61000-4-8 Power frequency magnetic fields | Class A |
| EN 61000-4-2 ESD 3.)                         | Class B |