

# Data Sheet for Linear Sensors

## Potentiometric Linear Transducer

## Series MBF

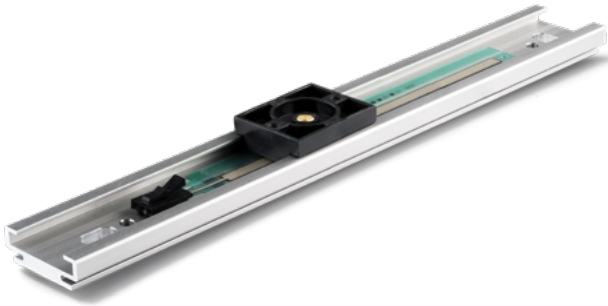

The MBF series features a low profile of < 14mm and a minimalist design. The slider is conveniently designed for direct and space saving integration into the application. The transducer is electrically connected via the integrated crimp connector. A matching mating connector with cable is available as an accessory (not included).

- 50 mm to 500 mm measuring travel
- Over 3 million slider movements
- Overall height 13.6 mm
- Electrical connection with crimp plug

Electrical Data	
Effective electrical travel 1.)	100 mm (optional 50, 200, 300, 400, 500 mm)
Total resistance 1.)	7.5 kOhm
Resistance tolerance	±30 %
Independent linearity (best straight line) 1.)	±2 % (90% effective electrical travel)
Theoretical resolution 1.)	Almost infinite
Max. / recommended wiper current 1.)	1 mA (@ 40°C, 1 min in case of failure) / 0,1 µA
Power rating	≤ 0.25 W

Mechanical Data, Environmental Conditions, Miscellaneous	
Mechanical stroke 1.)	> 100 mm
Lifetime (90% effective electrical travel) 2.)	3 Mio. movements
Max. operational speed	< 3 m/s
Operational force @ RT 1.) 2.)	< 1 N
End stop force	< 20 N
Operational temperature	-25 °C up to +55 °C
Storage temperature	-30 °C up to +60 °C
Protection grade (IEC60529)	IP40
Sensor length	200 mm
Max. permissible perpendicular load on the slider	< 1 N
Mass	about 65 g
Mounting parts (not included in delivery)	For example: Screws M5 ISO7380
Materials	Plastic, Aluminium

1.) According IEC 60393

2.) Determined by climatic conditions according to IEC 68-1, para. 5.3.1 without load collectives

Please note: Max. permissible supply voltage ≤42 VDC respectively ≤42 VAC in addition the max. power rating must be observed

# Data Sheet for Linear Sensors

Potentiometric Linear Transducer

Series MBF

## Order Code

Description	Selection: <b>standard=black/bold</b> , possible <i>options=grey/italic</i>				
<b>Series</b>	<b>MBF</b>				
<b>Effective electrical travel:</b>					
<i>Option 50 mm</i>			50		
<b>100 mm</b>			<b>100</b>		
<i>Option 200 mm</i>			200		
<i>Option 300 mm</i>			300		
<i>Option 400 mm</i>			400		
<i>Option 500 mm</i>			500		
<b>Total resistance:</b>					
<b>100 mm 7,5 kOhm</b>				<b>R7,5K</b>	
<i>(Resistance for other lengths depending on the electrical travel)</i>				<i>Rxxx(K)</i>	
<b>Resistance tolerance:</b>					
<b>100 mm (±30%)</b>					<b>W30%</b>
<b>Independent linearity:</b>					
<b>≤±2%</b>					<b>L2%</b>

**For higher quantities or on-going demand, additional options are available as described below on request**

For example:

- Assembled stranded wires and cables with/without connectors
- Opt. crimp mating connector #135800
- Higher temperature range
- With end stops and round cable

# Data Sheet for Linear Sensors



## Potentiometric Linear Transducer

Series MBF

### Drawing

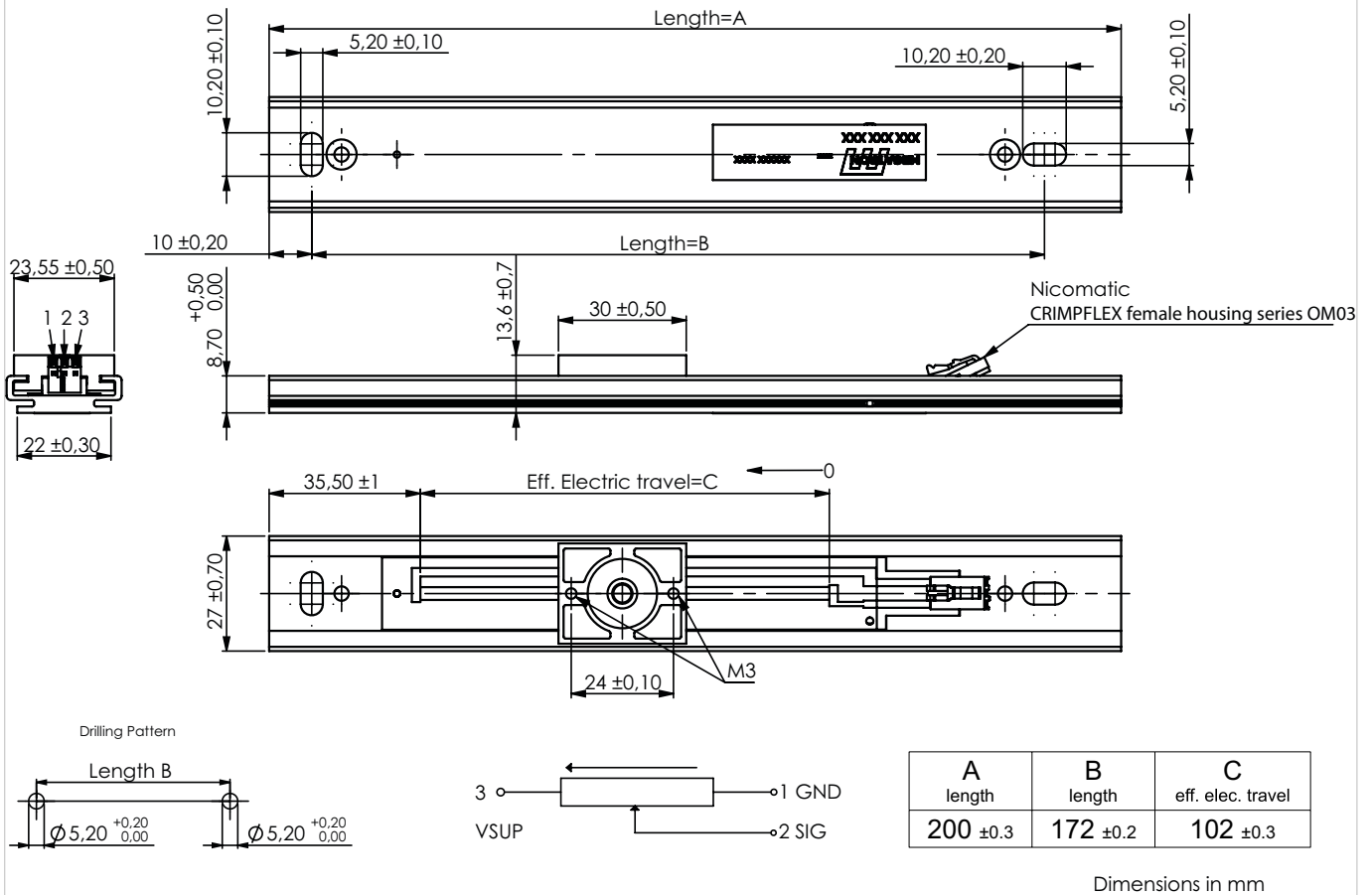

### Drawing accessory (not included in delivery)

