

Data Sheet for Joysticks

Finger Joystick

Series 848



- Very robust joystick
- Low size over panel < 42 mm
- Small installation depth of < 26 mm
- Contact-less, wear-free Hall effect technology
- Reliability through redundant Hall sensors (optional)
- Ideally suited for applications with high mechanical demands

The series 848 offers low-profile joysticks and is suited for harsh conditions. The series uses modern Hall effect sensors, and exhibits robust mechanics (max. load 400 N) with up to 10 million lifecycles. A special feature are the Center Detect and Center Tap outputs for non-redundant versions.

Technical Data

Sensor technology	Hall Effect
Supply voltage*	5.0 ± 0.5 VDC transient free
Voltage in center position*	2.5 V
Return to center accuracy	±5% of maximum output
Output impedance	10 Ohm
Impedance	Min. 10 kOhm, > 100 kOhm recommended
Life cycles	10 Mio. cycles (5 Mio. with 3 axes)
Output signal	0 to 5 V / 0.5 to 4.5 V (others on request)
Supply current	<13 mA (2 axes) / <20 mA (3 axes)
Angle of movement X-, Y-axis / Z-axis	36° (±18° from center) / 50° (±25° from center)
Operating force X-Y-axis	Breakout force standard typ. 1.3 N (1.0 to 2.5 N available on request)
Max. vertical load to mechanism	400 N
Operating / Storage temperature	-30°C to +85°C / -40°C to +110°C
Above panel sealing	IP66
EMC emission	CISPR 16-1, 16-2 30-230 MHz/230-1000MHz/1-3 GHz/3-6 GHz, 50 dBµV/m/57 dBµV/m/76 dBµV/m/80 dBµV/m
EMC immunity	EN61000-4-3 80 MHz-6 GHz, 10-1 V/m plus, 80MHz-2.7GHz, 100V/m (Extended)
ESD	EN61000-4-2 (extended) ±8 kV & ±15 kV
Power-frequency magnetic field	IEC 61000-4-8 30 A/m elevated to 400 A/m
Electromagnetic fields	4 mT static magnetic field (3200A/m DC)
Radio-frequency common mode	IEC 61000-4-6 150 kHz-80 Mhz, 10 V
Fast transients on signal ports	IEC 61000-4-4 ± 2 kV
Fast transients on power ports	IEC 61000-4-4 ± 2 kV
Surges on signal ports	IEC 61000-4-5 ± 1 kV
Free fall	1 m
Random vibration for handheld device	IEC 60068-2-64

*The output voltage is ratiometric to the supply voltage. We therefore suggest to use low-noise, stabilized power supplies.

Data Sheet for Joysticks

Finger Joystick

Series 848

Mechanism

The omni-directional mechanism features an extremely robust ball-socket pivot. This construction yields a product that is very resistant to vertical impact, and constantly withstands high pull, push, rotational or horizontal forces.

Magnetic screening

The 848 series incorporates internal magnetic screening to minimize the effect of external magnetic fields. Nevertheless, we do not recommend mounting or operating the joystick close to strong magnetic fields.

Please contact us for information regarding stock articles, delivery times and minimum order quantities.

Order Code

Description	Selection: standard= black/bold , possible options= <i>grey/italics</i>							
Series	848							
Axes: <i>1 Axis</i>		<i>1</i>						
2 Axes		2						
Bezel: <i>No bezel, below panel mounting</i>			<i>1</i>					
Square bezel, drop-in mounting			2					
Return Mechanism: <i>Spring return with weak spring (1 N)¹</i>				<i>6</i>				
Spring return with standard spring (1.3 N)¹				1				
<i>Spring return with stronger spring (1.6 N)¹</i>				<i>8</i>				
<i>Spring return with extra strong spring (2.5 N)¹</i>				<i>9</i>				
Handle types: Handle A, castle, black, Nylon					A			
<i>Handle B, dome, black, Nylon</i>					<i>B</i>			
Limiter: <i>Round</i>						<i>5</i>		
Square						6		
<i>Single Axis, Y direction²</i>						<i>2</i>		
<i>X/Y Plus "+"</i>						<i>3</i>		
Output options: Standard analogue 5 V (single)							S	
<i>Dual redundant analogue 5 V, parallel output</i>							<i>P</i>	
<i>Dual redundant analogue 5 V, inverse/crossed output</i>							<i>I</i>	
<i>PWM (Pulse width modulation)</i>							<i>W</i>	
<i>CAN J1939</i>							<i>7</i>	
<i>CANopen</i>							<i>8</i>	
<i>Single analogue 3.3 V stabilized</i>							<i>L</i>	
Signal details: 0 to 100% (0 to 5.0 V or 0 to 3.3 V)								5
<i>10 to 90% (0.5 to 4.5 V or 0.33 to 2.97 V)</i>								<i>4</i>
<i>PWM/CAN</i>								<i>-</i>

¹ Break-out force from centre

² Limiter in x direction is not available, because this function is achieved by installing joystick rotated by 90°

³ "guided feel": The operation force needed for the main axes is slightly below the force needed for diagonal deflection.

For higher quantities or on-going demand, additional options are available

- Customer-specific cables
- Custom handles

Data Sheet for Joysticks

Finger Joystick

Series 848

Wiring, analogue, non-redundant versions

Pin	Function	Colour
1	Ground	black
2	Center Tap (desc. see below)	green
3	Z axis	purple
4	Y axis	yellow
5	X axis	blue
6	Vsupply	red
7	Center Detect (desc. see below)	orange
8**	Pushbutton	orange
9**	Pushbutton	orange

Orientation / Polarity

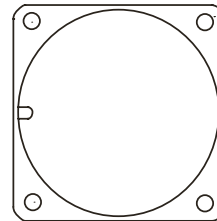
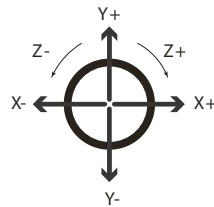

CABLES EXIT TO THE EAST WHEN VIEWED FROM ABOVE

Pin 8 (orange)  (orange) Pin 9

** For custom versions with pushbutton. The both wires are separate connectors for the n.o. switch.

Cable harness (analogue versions only)

The joysticks are delivered with standard connection wires (2.5 mm raster, compatible to Molex KK series). For non-redundant versions without pushbutton, a 7-pin connector is delivered. For versions with pushbutton, a 9-pin connector is the default configuration. See the table below for pin configuration.

The wire length is ca. 150 mm. Please contact us for custom cable configurations.

Output impedance (analogue versions only)

The voltage outputs at the limits and at the center are specified for an infinite load at the outputs (no current flowing). Lower loads than 10 kOhms need to be avoided.

Center Tap (CT, analogue versions only)

The standard electronics (no redundancy) offers a center reference voltage output, that is set to 50% ($\pm 1\%$) of the supply voltage. This output can be used to check the integrity of the power supply. Voltage readings outside the tolerances suggest a problem with the power supply.

Another function of this output is as a reference relative to the center position of the joystick. Measuring the voltage output relative to the CT output, rather than relative to ground, eliminates inaccuracies caused by the power supply.

Center Detect (CD), analogue versions only

The standard electronics (no redundancy) offers a center detect output, which is 0 V if the joystick is inactive, but switches to high (5 V if operated with 5 V power supply) only if the joystick is operated.

In the internal electronics, this output is pulled high by a 2K2 resistor and is decoupled by a 100 nF capacitor to 0 V.

This output is designed for use in applications requiring an enable/disable signal that is separate from the main wipers. We do not recommend to use this as a safety feature or a method of "person-present" detection (deadman).

Handle Types

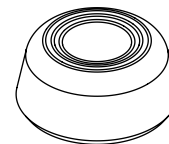

Handles	A	B
Material	Nylon	Nylon
Finish	Sparked Matt	Sparked Matt
Standard colour	Black	Black
Notes		

Drawing (output options S, P, I, W, L)

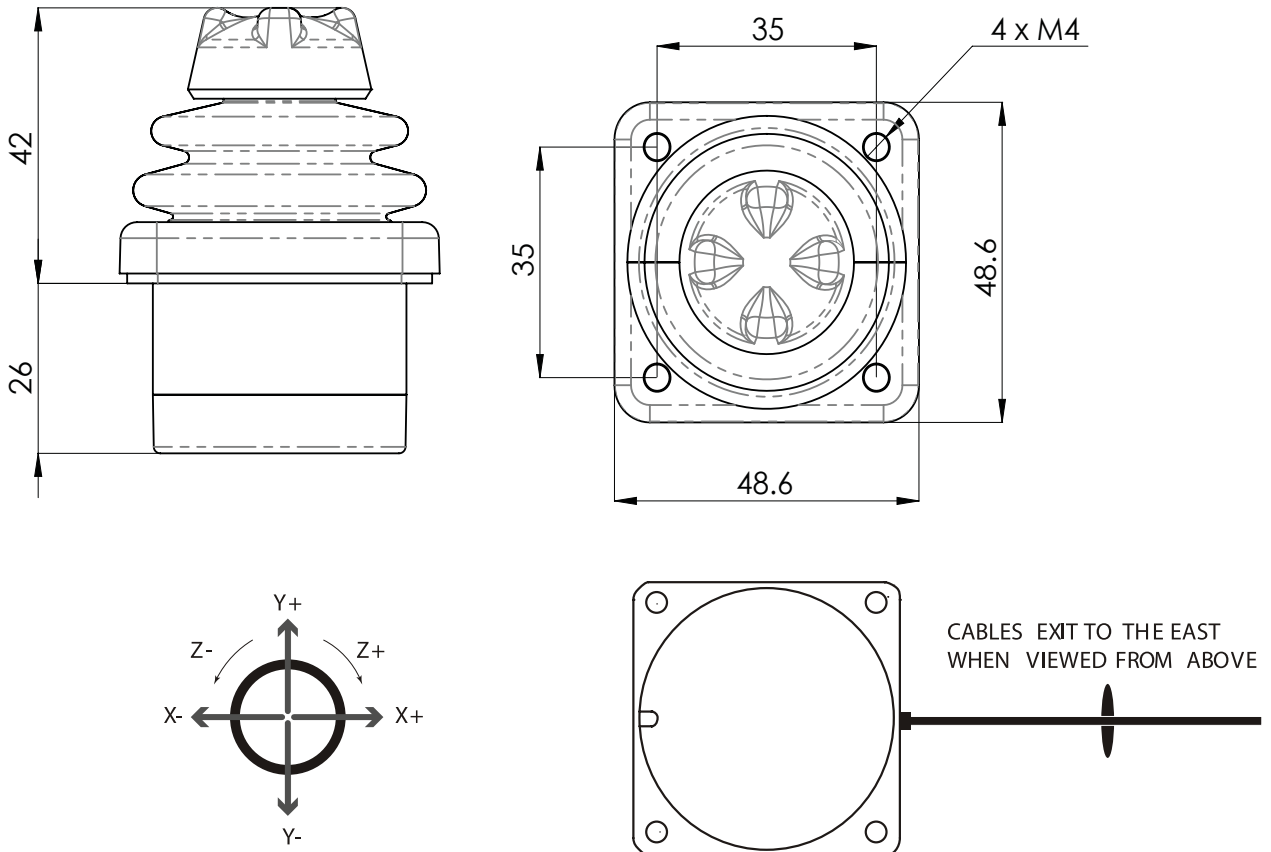

Dimensions are in mm

Spring return

The standard force required for the deflection is 1.3 N. On request, also weaker (1.0 N) or stronger springs can be selected (1.6 N, 2.5 N).

Limiters



Square - Option 6



Circular - Option 5



Single Axis Y - Option 2



X/Y Plus "+" - Option 3

Option 5 and 6: The operation force needed for the main axes is slightly below the force needed for diagonal deflection ("guided feel").

Data Sheet for Joysticks

Finger Joystick

Series 848

Termination for CAN outputs only

Pin	Function CAN J1939	Function CANopen	Colour
1	Supply (7 to 35 VDC)	Supply (7 to 35 VDC)	red
2	Ground	Ground	black
3	ID select MSB	Node ID select MSB	orange
4	ID select LSB	Node ID select LSB	blue
5	CAN High	CAN High	green
6	CAN Low	CAN Low	white

CAN output versions are supplied with on-board 6 way connector. Header specifications: JST S6B-PH-K-S(LF) (SN), 6 position, 2mm pitch, single row header (see drawing below).

Technical data CAN J1939 version (output option 7)

The 844 series can be configured with a maximum of 3 proportional axes and with a maximum of 2 buttons. The axis information and button data are transmitted via a CAN 2.0B-compatible physical interface. Two additional wires allow the address of the controller to be configured. The controller transmits its information in accordance with the SAE J1939-71 protocol.

Transmission repetition rate	50 ms
Terminal resistor	None
Baud rate	250 kbit/s
CAN ID format	29 bit (CAN 2.0B)
BJMI/EJMI interval time	20 ms

Data CAN J1939-71 protocol (output option 7)

- Primary axis and Pushbutton data on Basic Joystick Message 1 (BJM1):
 - Priority: 3
 - PGN: 0xFDD6
 - Source address: 0x16⁽¹⁾
 - Length of data field: 8 bytes

- Redundant axis and Pushbutton data on Extended Joystick Message 1 (EJM1):
 - Priority: 3
 - PGN: 0xFDD7
 - Source address: 0x16⁽¹⁾
 - Length of data field: 8 bytes

⁽¹⁾ Alternative source addresses can be configured by grounding the blue and / or orange wires:

- Source address = 0x16: ORANGE = floating, BLUE = floating (standard)
- Source address = 0x26: ORANGE = floating, BLUE = grounded
- Source address = 0x36: ORANGE = grounded, BLUE = floating
- Source address = 0x46: ORANGE = grounded, BLUE = grounded

BJM1 data field configuration (output option 7)

Start position (BYTE/BIT)	Length (BITS)	Function
1/1	2	Primary data X-axis, status neutral position
1/3	2	Primary data X-axis, status left position (minimum value)
1/5	2	Primary data X-axis, status right position (maximum value)
1/7 to 2/8	10	Primary data X-axis, axis position
3/1	2	Primary data Y-axis, status neutral position
3/3	2	Primary data Y-axis, status backward position (minimum value)
3/5	2	Primary data Y-axis, status forward position (maximum value)
3/7 to 4/8	10	Primary data Y-axis, axis position
6/5	2	Button 2 status
6/7	2	Button 1 status

Data Sheet for Joysticks

Finger Joystick

Series 848

EJM1 data field configuration (output option 7)

Start position (BYTE/BIT)	Length (BITS)	Function
5/1	2	Z axis primary data, neutral position status
5/3	2	Primary data Z axis status deflection counterclockwise
5/5	2	Primary data Z-axis status deflection clockwise
5/7 to 4/8	10	Primary data Z axis, axis position

*Redundant outputs are available as a special version

Technical data CANopen version (output option 8)

The 844 series can be configured with a maximum of 3 proportional axes and 2 buttons. Two additional lines allow the address of the controller to be configured. The following configuration applies to the CANopen® protocol.

Node ID:	20h
Baud rate:	250 kbit/s
Push button data:	Button status is transmitted in a 1 byte data frame with the identifier 1A0 (180h + node ID)
Axis data:	Axis data are transmitted in a 3 byte data frame with the identifier 2A0 (280h + node ID)
Heartbeat (500 ms):	720h (700h + node ID)
Axis resolution:	8 bit
Network management:	Autostart activated

Alternative node IDs can be configured by grounding the blue and/or orange wires:

- Node ID = 20H: ORANGE= floating, BLUE= floating (standard)
- Node ID = 21H: ORANGE= floating, BLUE= earthed
- Node ID = 22H: ORANGE= grounded, BLUE= floating
- Node ID = 23H: ORANGE= grounded, BLUE= grounded

Button data (output option 8)

Identifier	1A0
Byte 0	Buttons 2:0

Axis data (output option 8)

Identifier	2A0
Byte 0	A_IN0 [7:0]
Byte 1	A_IN1 [7:0]
Byte 2	A_IN2 [7:0]

For higher quantities or on-going demand, additional options are available

- Redundant joystick versions with CAN-bus
- Other Baud rates 125 kbit/s, 500 kbit/s, 1 Mbit/s
- Customer-specific CAN addresses and output configuration

Mounting Options

Drop-in of Joystick into panel cut-out.

For panel thickness < 3 mm, M3 x 16 countersunk machine screw are recommended. Also available with circular bezel.

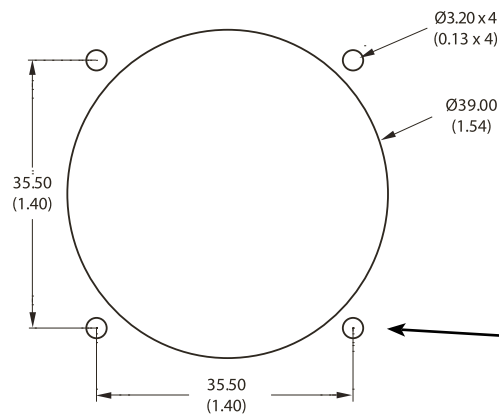
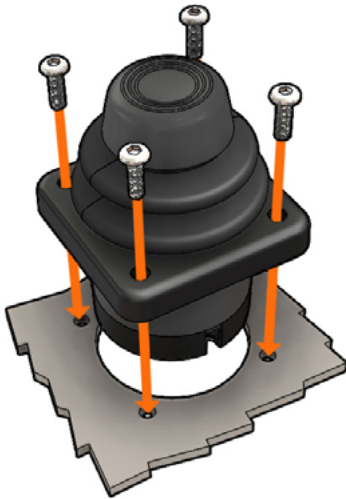

Slotted mounting holes - allows compatibility with mounting pitches of 32.25 mm to 35.80 mm

Mounting of Joystick from beneath the panel.

No bezel needed. M3 machine screws recommended.

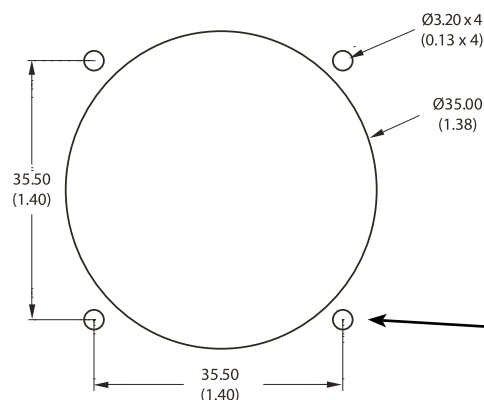
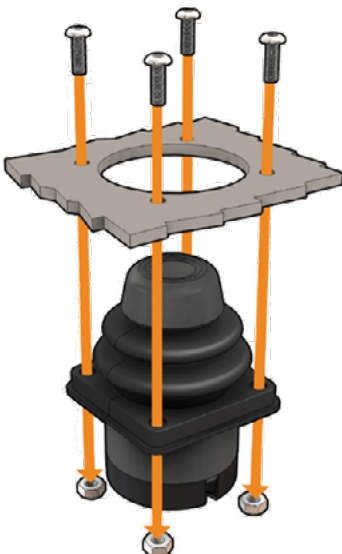

Slotted mounting holes - allows compatibility with mounting pitches of 32.25 mm to 35.80 mm

All Dimensions in mm