

Data Sheet for Precision adjustment Knobs

Precision adjustment Knob with Locking mechanism

Series IMT



IMT silver

The knob IMT with 50 dashes and revolution counter (20 rev.) in Ø22 mm housing has a locking mechanism. The lock prevents unintentional adjustments.

- Knob with 50 dashes
- Revolution counter for 20 revolutions
- With locking mechanism
- For 3..6.35 mm shaft

The IMT series allows a very precise manual handling with up to 20 revolutions (50 dashes per revolution). The knob is used often with a multi-turn potentiometer (e.g. AL17/19).

Data adjustment knob

Number of full revolutions	20
Counter range of the adjustment knob	Scale with numbers (50 dashes) and revolution counter (20 revs)
Brake available	yes
For shaft diameter	3 / 3.175 / 4 / 6 / 6.35 mm
Shaft length (of sensor) over panel	max. 23 mm, min. 16 mm
Housing diameter	22 mm
Housing depth	25 mm (with knob)
Knob diameter	Conical from 10 mm (front) to 12 mm (end)
Operating temperature range	-30 °C up to +60 °C
Storage temperature range	-30 °C up to +60 °C
Protection grade (IEC 60529)	IP40
Colour housing	Silver or black
Colour adjustment knob	Black with white scale
Material knob/housing	Reinforced fibreglass and metal
Mass	ca. 5 g
Mounting parts included in delivery	Hexagon socket wrench

Order code

Description	Selection: standard=black/bold , possible <i>options=grey/italic</i>				
Series	IMT				
For shaft diameter:					
Ø 6,35		1/4"			
Ø 6,00		6 MM			
Ø 4		4 MM			
Ø 3		3 MM			
Ø 3,175		3,17 MM			
Housing colour:					
Silver			-		

Data Sheet for Precision adjustment Knobs

Precision adjustment Knob with Locking mechanism

Series IMT

Drawing

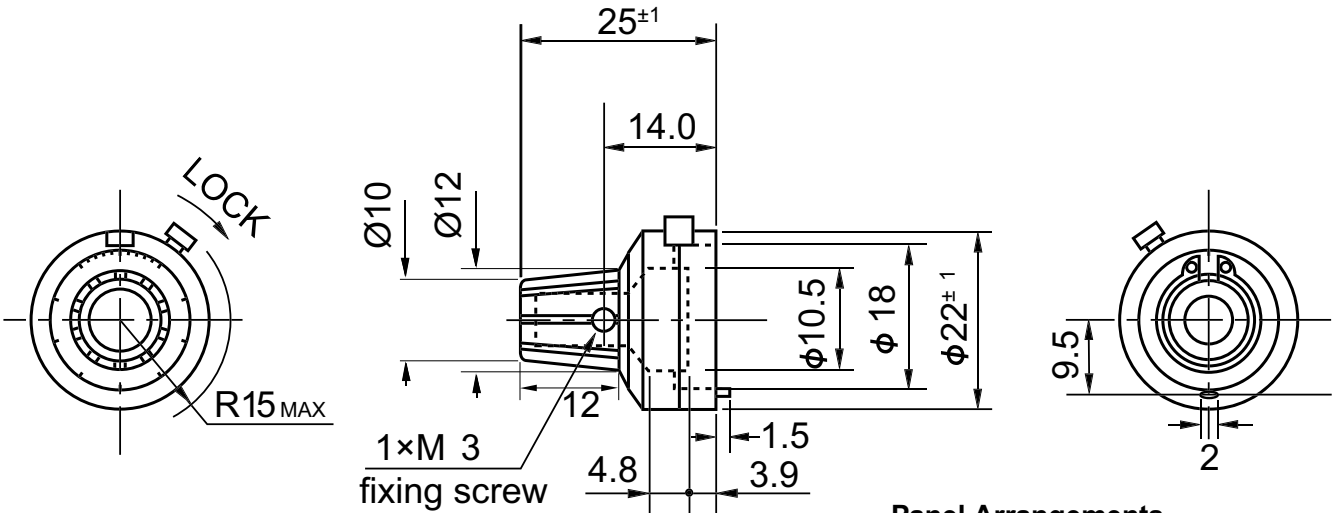

Panel Arrangements

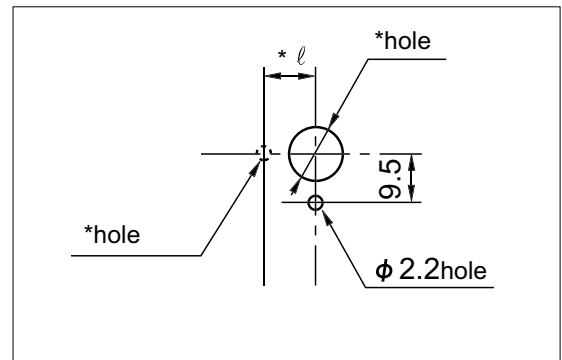

50 divisions in inner graduation (Possible read out of 1/500 in case of 10-turn pot).

*Determined by the pot to be mounted

