

Data Sheet for Joysticks

Hand Joystick

Series TRY54



- Heavy-Duty Joystick with CAN J1939-71 or CANopen interface
- SIL 2 compatible - redundant hall sensors
- Shallow mounting depth < 60 mm
- 10 million cycles resisting high axial load (up to 1780 N)
- Multifunction handle providing space for additional functional elements (pushbutton switches, rockers, thumb joysticks, etc.)

Joystick of the TRY54 series were developed focussing on highly demanding heavy-duty and off-road applications. Use of metal components and optimized dimensioning of the mechanism and control lever result in an individually configurable joystick with the reliability of larger models and significantly reduced dimensions.

Electrical Data Joystick

Sensor	Redundant Hall Sensors
Supply Voltage	6 - 35 VDC
Reverse polarity max.	-1000 VDC
Transient overvoltage max.	40 V
Output signal	SAE CAN J1939-71 or CANopen
Connection (CAN J1939-71)	Deutsch DTM04-6p

Mechanical and Environmental Data Joystick

Deflection angle	40° (±20° from center)
Maximum axial load	1780 N
Expected life	10 million lifecycles (X and Y axis)
Sealing (above panel)	Up to IP67 (subject to handle configuration)
Operating Temperature	-40 °C .. +85 °C
Storage Temperature	-40 °C .. +85 °C
Humidity	IEC 60068-2-38
Thermal Shock	SAE J1455 section 4.1.3.2
Salt spray	IEC 60068-2-11
Random vibration	IEC 60068-2-64
Sinusoidal vibration	IEC 60068-2-6
EMV Emissions	Radiated Emissions Level: ECE/324/Add.9:2012; CISPR 25:2002 Radiated Emissions Level: CISPR 25:2008
EMC Immunity	ESD: ISC 10605:2008; criteria A Radiated Immunity: ISO 11452-2:2004; criteria B Bulk current injected immunity: ISO 11452-4:2011; criteria A Pulse 1, Pulse 2a, Pulse 2b, Pulse 3a, Pulse 3b, Pulse 4, Pulse 5a: ISO 7637-2:2011; criteria A

Notes:

1. All values are nominal
2. Exact specifications may be subject to configuration

Data Sheet for Joysticks

Hand Joystick

Series TRY54

Pushbuttons Characteristics

Max. Current / Voltage Rating with Resistive Load	3 A 28 VDC
Low Level	1 GOhm min. at 500 VDC
Electrical Life at Full Load	25000 cycles
Mechanical Life	1 million cycles
Environmental Seal	IP67 IEC 60529
Action	Momentary, normally-open
Operating Force	7 N \pm 3 N
Total Travel	1.7 mm \pm 0.3 mm
Pushbutton Colors available	White, Grey, Black, Red, Orange, Yellow, Green, Blue

Faceplate configuration options (other individual realizations possible)

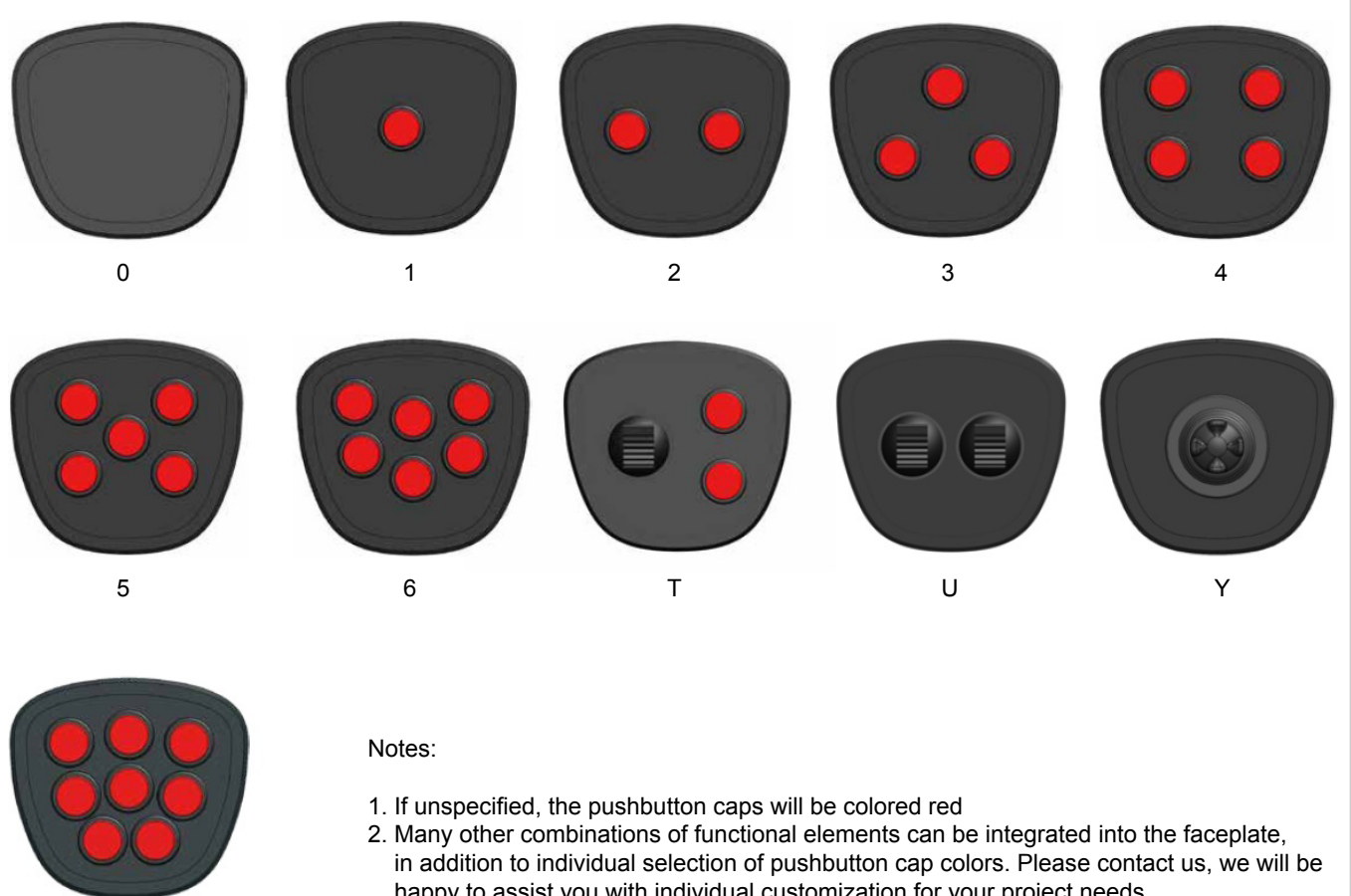

0 1 2 3 4

5 6 T U Y

8

Notes:

1. If unspecified, the pushbutton caps will be colored red
2. Many other combinations of functional elements can be integrated into the faceplate, in addition to individual selection of pushbutton cap colors. Please contact us, we will be happy to assist you with individual customization for your project needs.

Data Sheet for Joysticks

Hand Joystick

Series TRY54

Order Code

Series	TRY54								
Axes									
2		2							
Rubber Boot									
			5						
Return Mechanism									
Spring „Standard“				1					
Limiter									
Square					1				
Output Signal									
SAE CANbus J1939-71									
CANopen						CAN COP			
Faceplate configuration									
None							0		
1 Pushbutton							1		
2 Pushbuttons							2		
3 Pushbuttons							3		
4 Pushbuttons							4		
5 Pushbuttons							5		
6 Pushbuttons							6		
8 Pushbuttons							8		
1 Toggle Switch, 2 Pushbuttons							T		
2 Toggle Switches							U		
Mini joystick TRY14							Y		
Customized							X		
Trigger									
None								0	
Index Trigger								1	
Deadman function									
None									0
Deadman paddle									1

Data Sheet for Joysticks



Hand Joystick

Series TRY54

Technical Drawing

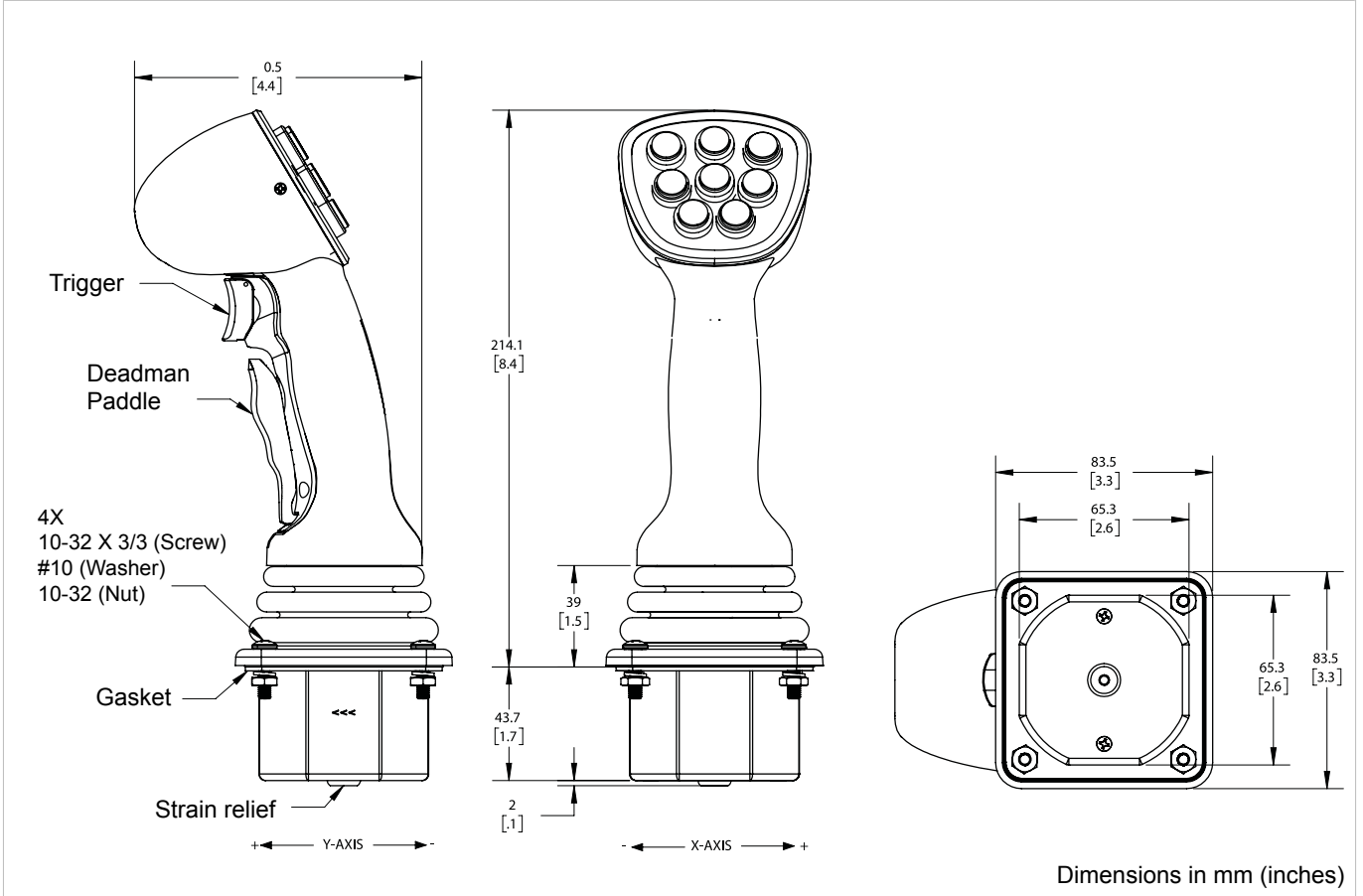

Panel Cut-Out

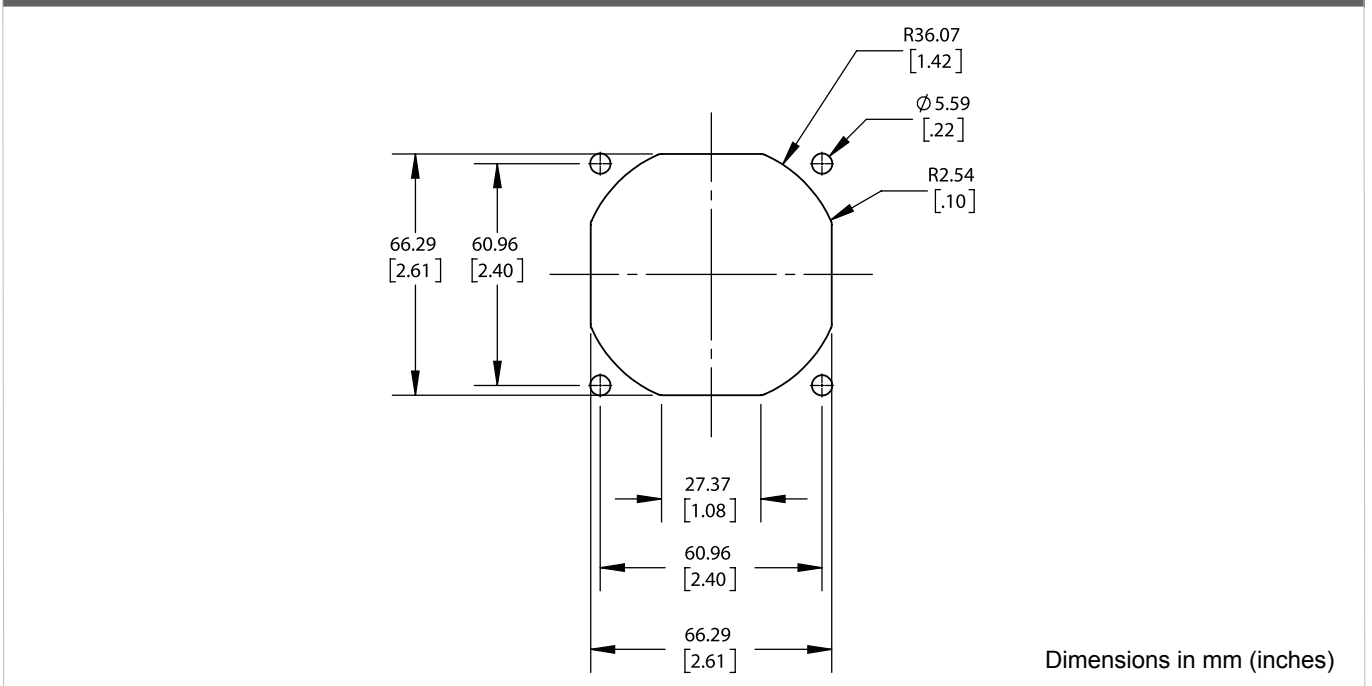

Data Sheet for Joysticks

Hand Joystick

Series TRY54

Connection to Deutsch-Stecker DTM04-6P

PIN	WIRE COLOR	FUNCTION
1	WHITE	CAN low data
2	GREEN	CAN high data
3	BLUE	Source Address SEL 1
4	ORANGE	Source Address SEL 0
5	BLACK	Ground
6	RED	6 - 35 VDC

Standard cable length ca. 150 ±1.3 mm; wire AWG 22, PTFE Insulation.
Individual cable configuration available upon request.

CAN J1939 Interface Parameters*

All axis and button data are delivered on a CAN 2.0B compliant physical interface. Two additional signals allow configuration of the controller Source Address. Controller messages are delivered per the SAE J1939-71 message protocol.

Baud Rate	250 kHz
Transmission repetition rate	50 ms
BJMI/EJMI interval time	20 ms
Terminating resistor	No (available upon request.)

*Information about CANopen interface on request

CAN Message Protocol

• Primary Axis and button data on Basic Joystick Message 1 (BJM1):

- Priority: 3
- Base PGN: 0xFDD6
- Source address: 0x10⁽¹⁾
- Data field: 8 bytes

Redundant Axis data on Extended Joystick Message 1 (EJM1):

- Priority: 3
- Base PGN: 0xFDD7
- Source address: 0x10⁽¹⁾
- Data field: 8 bytes

• Additional thumbwheels and mini-joysticks data on Extended Joystick Message 2 (EJM2):

- Priority: 3
- Base PGN: 0xFDD9
- Source address: 0x10⁽¹⁾
- Data field : 8 bytes

⁽¹⁾ Alternate source addresses can be configured by grounding of the blue and/or orange wires.

- Source address= 0x10: ORANGE= floating , BLUE= floating (default)
- Source address= 0x20: ORANGE= floating, BLUE= grounded
- Source address= 0x30: ORANGE= grounded, BLUE= floating
- Source address= 0x40: ORANGE= grounded, BLUE= grounded

Data Sheet for Joysticks

Hand Joystick

Series TRY54

BJM1 DATA FIELD STRUCTURE

START POSITION (BYTE/BIT)	LENGTH (BITS)	FUNCTION
1/1	2	Primary X-axis neutral position status
1/3	2	Primary X-axis left position status
1/5	2	Primary X-axis right position status
1/7 to 2/8	10	Primary X-axis position data
3/1	2	Primary Y-axis neutral position status
3/3	2	Primary Y-axis down position status
3/5	2	Primary Y-axis up position status
3/7 to 4/8	10	Primary Y-axis position data
6/1	2	Button 4 status
6/3	2	Button 3 status
6/5	2	Button 2 status
6/7	2	Button 1 status
7/1	2	Button 8 status (Paddle if 6 button configuration)
7/3	2	Button 7 status (Trigger if 6 button configuration)
7/5	2	Button 6 status
7/7	2	Button 5 status

EJM1 DATA FIELD STRUCTURE

START POSITION (BYTE/BIT)	LENGTH (BITS)	FUNCTION
1/1	2	Redundant X-axis neutral position status
1/3	2	Redundant X-axis left position status
1/5	2	Redundant X-axis right position status
1/7 to 2/8	10	Redundant X-axis position data
3/1	2	Redundant Y-axis neutral position status
3/3	2	Redundant Y-axis down position status
3/5	2	Redundant Y-axis up position status
3/7 to 4/8	10	Redundant Y-axis position data

EJM2 DATA FIELD STRUCTURE

START POSITION (BYTE/BIT)	LENGTH (BITS)	FUNCTION
1/1	2	A-axis neutral position status
1/3	2	A-axis left position status
1/5	2	A-axis right position status
1/7 to 2/8	10	A-axis position data
3/1	2	B-axis neutral position status
3/3	2	B-axis left position status
3/5	2	B-axis right position status
3/7 to 4/8	10	B-axis position data
5/1	2	C-axis neutral position status
5/3	2	C-axis left position status
5/5	2	C-axis right position status